

Contents

F3XH04 High-Speed Input Module.....	3
F3XA08, F3XA16, F3XC08, F3XD08, F3XD16, F3XD32 and F3XD64 Input Modules	5
F3YD04, F3YA08, F3YC08, F3YC16, F3YD08, F3YD14, F3YD32 and F3YD64 Output Modules.....	13
F3YD32-1H High-Speed Transistor Output Modules (sink type with short-circuit protector)	21
F3YD32-1P, F3YD64-1P Transistor Output Modules (sink type with short-circuit protector).....	23
F3YD32-1R, F3YD64-1R Transistor Output Modules (source type with short-circuit protector)	27
F3WD64-xP Input/Output Modules (sink type with short-circuit protector).....	31
TA40 Terminal Block Unit	35
TA50-0N, TA50-1N, TA50-2N Connector Terminal Block Unit KM55-0xx Connector Terminal Block Cable	37

Blank Page

General Specifications

F3XH04 High-speed Input Module

FA-M3

General

The F3XH04 is a high-speed input module which incorporates the pulse-capture features of the FA-M3.

- The pulse-capture features facilitate detection of pulse inputs with shorter on-time than the scan period, which allows the F3XH04 to carry out photo-micro switch input for high-speed sensing.
- The interrupt mechanism ensures reliable interrupt processing using a short on-time pulse input.
- The minimum pulse width is as short as 50 μs.
- The four-independent input system permits connection from different signal systems.
- The terminal block is provided with terminals for shielded cables.

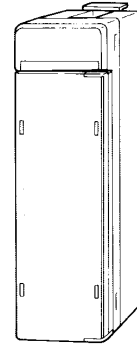

Specifications

Item	Specification	
Input type	DC voltage	
Number of inputs	4	
Common system	4 independent inputs	
Isolation method	Photocoupler isolation	
Rated input voltage	24 V DC	
Operating voltage range	20.4 - 26.4 V DC	
Rated input current	11.2 mA/point (24 V DC)	
Input impedance	2.1 KΩ	
Operating voltage/current	ON	16.0 V DC min. 7.2 mA min.
	OFF	6.0 V DC max. 2.5 mA max.
Input response time	OFF → ON	50 μs max.
	ON → OFF	50 μs max.
Minimum input pulse width	50 μs	
Pulse capture features*	Selection	By DIP switches.
	Setting	By DIP switches.
Interrupt features*	Setting	Set for each point through Ladder Diagram Support Program M3
	Input hold time	The input signal is held for 512 μs after detection of an off-to-on transition.
Current consumption	30 mA (5 V DC)	
External connection	10-point terminal block, M3.5 screw	
Weight	130 g	
Surrounding air temperature range	Operating	: 0 to 55°C
	Storage	: -20°C to 75°C
Surrounding humidity range	Operating	: 10 to 90% RH (non-condensing)
	Storage	: 10 to 90% RH (non-condensing)
Surrounding atmosphere	Must be free of corrosive gases, flammable gases or heavy dust.	

*: The pulse-catch and interrupt features are not available at the same time.

Components and Functions

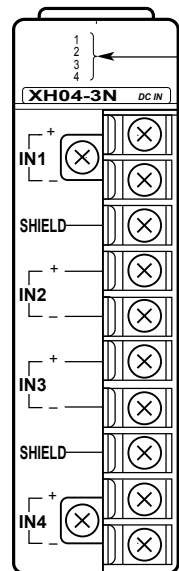

Input LEDs :
Indicates the on/off status of inputs.

Terminal block :
10-point detachable terminal block. The terminal screws are M3.5 screws with square captive washers.

Internal Circuit Diagram

F3XH04-3N (High-speed input module)

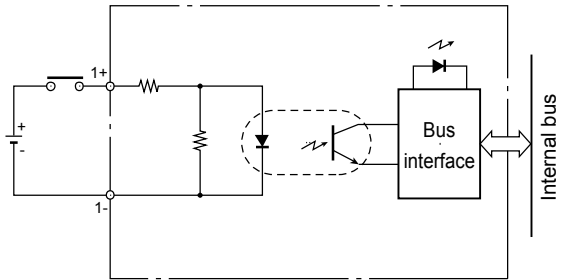

External Connection Diagram

F3XH04-3N (High-speed input module)

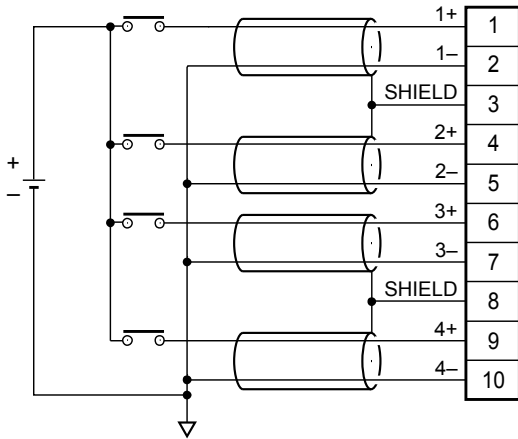

External Dimensions

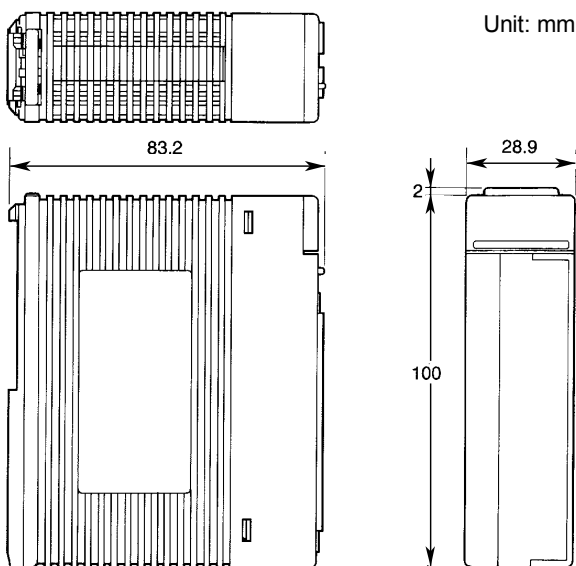

External Connection Method

		Terminal Block Type
Applicable conductor size		0.33-0.82 mm ²
Wire connection method		Solderless
Solderless terminal	Solderless terminal	For 3.5 mm terminals
	Crimping torque	0.8 N·m (8 kgf·cm, 6.9lbf·in)
	Applicable solderless terminal	Example: Japan Solderless Terminal Mfg. Co., Ltd.:V1.25-M3 Nippon Tanshi Co., Ltd.: RAV1.25-3.5

Operating Environment

There is no restriction on the type of CPU modules that can be used with this module.

Model and Suffix Codes

Model	Suffix Code	Style Code	Option Code	Description
F3XH04	-3N	High-speed inputs with pulse-capture feature, 24 V DC, 4 points

General Specifications

FA-M3

F3XA08, F3XA16, F3XC08, F3XD08, F3XD16, F3XD32 and F3XD64 Input Modules

General

The input modules for the FA-M3 are listed below. Select the most appropriate modules according to your applications.

- F3XA08-1N AC input module
- F3XA08-2N AC input module
- F3XA16-1N AC input module
- F3XC08-0C No voltage contact input module
- F3XC08-0N No voltage contact input module
- F3XD08-6F DC input module
- F3XD16-3F DC input module
- F3XD16-4F DC input module
- F3XD32-3F DC input module
- F3XD32-4F DC input module
- F3XD32-5F DC input module
- F3XD64-3F DC input module
- F3XD64-4F DC input module
- F3XD64-6M DC input module
- F3XD16-3H DC input module

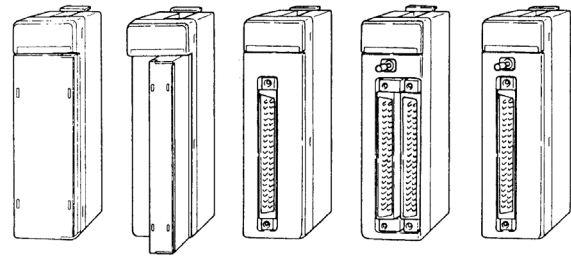

Components and Functions

The input modules are divided into terminal block and connector types as shown below.

Terminal Blocks

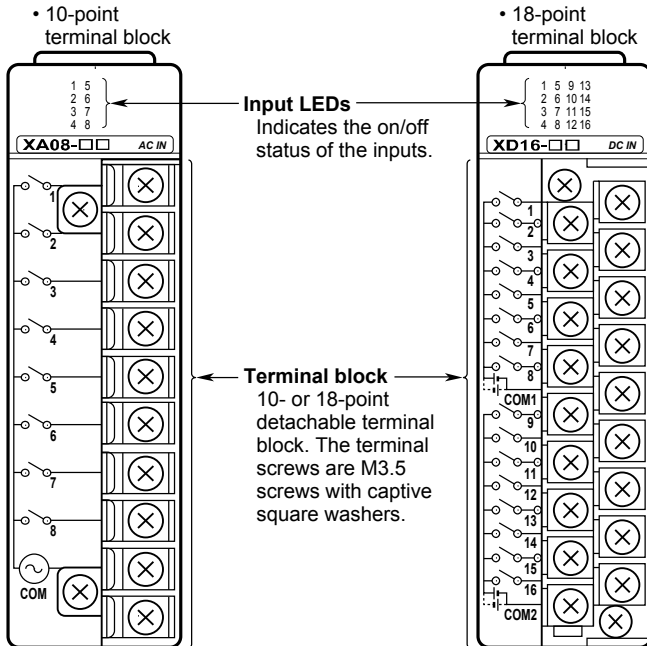

Connector type

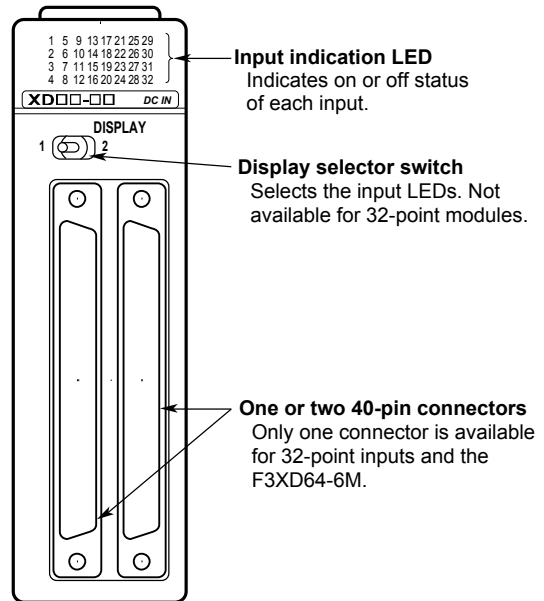

Display selector switch position	LED Indication
1	Indicates the on/off status of inputs 1 to 32.
2	Indicates the on/off status of inputs 33 to 64.

Specifications

Model	Input Type	Number of Inputs	Isolation Method	Rated Input Voltage	Rated Input Current	Operating Voltage Range	Operating Voltage/Current		Maximum ratio of inputs turned on simultaneously	Input response		External Connection	Points/ Common	Interrupt *2	Current Consumption	Weight			
							ON	OFF		OFF → ON	ON → OFF								
F3XA08-1N	AC voltage	8	Photocoupler isolation	100-120 V AC 50/60 Hz	5.4 - 6.5 mA/point 100-120V AC,60Hz	85-132 V AC 50/60Hz	80 V AC min. 5 mA min.	40 V AC max. 1 mA max.	100%	Selectable from 15 ms max. or 30 ms	Selectable from 25 ms max. or 40 ms	10-point terminal block M3.5 screw	8 points/ common	Can be specified for each input point.	40mA (5V DC)	130g			
F3XA08-2N				200-240 V AC 50/60 Hz	5.1 - 6.1 mA/point 200-240 V AC,60Hz	170-264 V AC 50/60Hz	160 V AC min. 4 mA min.	70 V AC max. 1 mA max. 40 V AC				18-point terminal block M3.5 screw			65mA (5VDC)	180g			
F3XA16-1N		16		100-120 V AC 50/60 Hz	5.4 - 6.5 mA/point 100-120 V AC,60Hz	85-132 V AC 50/60Hz	80 V AC min. 5 mA min.	40 V AC max. 1 mA max.							10-point terminal block M3.5 screw	40mA (5V DC)	130g		
F3XD08-6F	DC voltage (sink/ source)	8		12 - 24 V DC	4.1 mA/point (12V DC) 8.5 mA/point (24V DC)	10.2-26.4 V DC	8.0 V DC min. 2.6 mA min.	3.4 V DC max. 1.0 mA max.	100%	Input sampling time can be specified for 5 steps: Always (0µs), 62.5µs, 250µs, 1ms, and 16ms. *1,2	Input sampling time can be specified for 5 steps: Always (0µs), 62.5µs, 250µs, 1ms, and 16ms. *1,2	10-point terminal block M3.5 screw				8 points/ common	Can be specified for each input point.	40mA (5V DC)	130g
F3XD16-3F				24 V DC	4.1 mA/point 24 V DC	20.4 - 26.4 V DC	16.0 V DC min. 3.2 mA min.	5.8 V DC max. 0.9 mA max.				18-point terminal block M3.5 scr			65mA (5V DC)			160g	
F3XD16-4F		16		12V DC	4.1 mA/point 12 V DC	10.2 - 13.2 V DC	8.0 V DC min. 2.6 mA min.	3.4 V DC max. 1.0 mA max.							One 40-pin connector			75mA (5V DC)	120g
F3XD16-3H	DC voltage (plus common)	32		24 V DC	4.1 mA/point 24 V DC	20.4 - 26.4 V DC	16.0 V DC min. 3.2 mA min.	5.8 V DC max. 0.9 mA max.	100%	Input sampling time can be specified for 4 steps: Always (0µs), 62.5µs, 250µs and 1ms. *1,2	Input sampling time can be specified for 4 steps: Always (0µs), 62.5µs, 250µs and 1ms. *1,2	One 40-pin connector				8 points/ common	Can be specified for each input point.	100mA (5V DC)	160g
F3XD32-3F				24 V DC	4.1 mA/point 24 V DC	20.4 - 26.4 V DC	16.0 V DC min. 3.2 mA min.	5.8 V DC max. 0.9 mA max.							Two 40-pin connectors				
F3XD32-4F	DC voltage (sink/ source)	64		12V DC	4.1 mA/point 12 V DC	10.2 - 13.2 V DC	8.0 V DC min. 2.6 mA min.	3.4 V DC max. 1.0 mA max.	60%	Input sampling time can be specified for 4 steps: Always (0µs), 62.5µs, 250µs and 1ms. *1,2	Input sampling time can be specified for 4 steps: Always (0µs), 62.5µs, 250µs and 1ms. *1,2	Two 40-pin connectors				8 points/ common	Can be specified for each input point.	110mA (5V DC)	130g
F3XD32-5F				5V DC	4.0 mA/point 5 V DC	4.5 - 5.5 V DC	3.5 V DC min. 2.0 mA min.	1.0 V DC max. 0.2 mA max.											
F3XD64-3F	DC voltage (sink/ source)	64		24V DC	4.1 mA/point 24 V DC	20.4 - 26.4 V DC	16.0 V DC min. 3.2 mA min.	5.8 V DC max. 0.9 mA max.	60%	Input sampling time can be specified for 4 steps: Always (0µs), 62.5µs, 250µs and 1ms. *1,2	Input sampling time can be specified for 4 steps: Always (0µs), 62.5µs, 250µs and 1ms. *1,2	Two 40-pin connectors			8 points/ common	Can be specified for each input point.	110mA (5V DC)	130g	
F3XD64-4F				12 V DC	4.1 mA/point 12 V DC	10.2 - 13.2 V DC	8.0 V DC min. 2.6 mA min.	3.4 V DC max. 1.0 mA max.											
F3XD64-6M	Matrix scan				12 - 24 V DC	3.9 mA (12 V DC) 8.2 mA (24 V DC)	10.2 - 26.4 V DC	8.0 V DC min. 2.6 mA min.	3.4 V DC max. 1.0 mA max.	-	16 ms max.	16 ms max.			One 40-pin connector	8 x 8 matrix		110mA (5V DC)	130g

Note: See external dimensions for dimensions of the modules.

*1: When F3SP28, F3SP38, F3SP5x, F3SP6x or F3SP7x is used. For other CPU modules, the specification is the same as the F3XDxx-xN. The actual response time can be obtained by adding the following values:

For F3XDxx - xF: 100 µs (OFF → ON)
300 µs (ON → OFF)

For F3XD16-3H: 10 µs

*2: If the input interrupt is to be used with the F3XDxx - xF, set the input sampling period to at least 62.5 µs.

Model	Input Type	Number of Inputs	Isolation Method	Contact Ratings	ON Resistance	OFF Resistance	Maximum ratio of inputs turned on simultaneously	Input response		External Connection	Points/Common	Interrupt *2	Current Consumption	Weight
								OFF→ON	ON→OFF					
F3XC08-0C	No-voltage contact	8	Transformer isolation	5 V DC min. 20 mA max.	200 Ω max.	100 kΩ min.	100%	Input sampling time can be specified for 5 steps: Always (0μs), 62.5μs, 250μs, 1ms, and 16ms *2 (Response time is sampling period + 1 ms max.)	Input sampling time can be specified for 5 steps: Always (0μs), 62.5μs, 250μs, 1ms, and 16ms *2 (Response time is sampling period + 1 ms max.)	10-point terminal block M3.5 screw	Separate commons	Can be specified for Each input point.	75mA	170g
F3XC08-0N								Selectable from 2.0 ms max. or 17 ms	Selectable from 2.0 ms max. or 17 ms		8 points/common			140g

Note: See external dimensions for dimensions of the modules.

*2: If the input interrupt is to be used, set the input sampling period to at least 62.5 μs.

Internal Circuit Diagram

F3XA08-1N
F3XA08-2N
F3XA16-1N

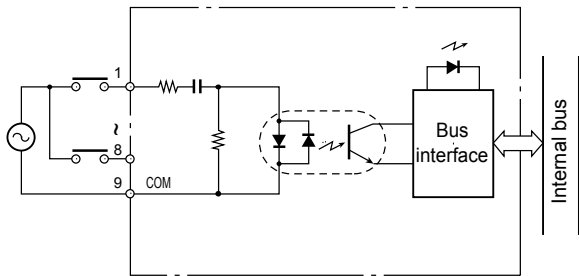

F3XC08-0C

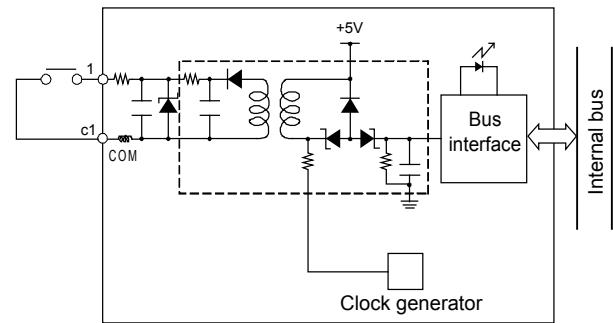

F3XD08-6F
F3XD16-3F
F3XD16-4F

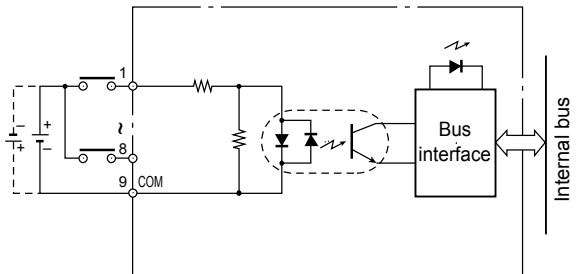

F3XC08-0N

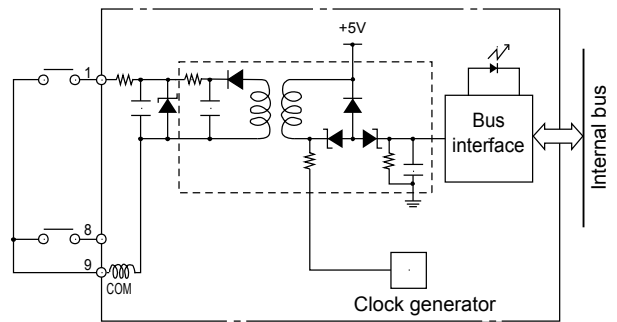

F3XD16-3H

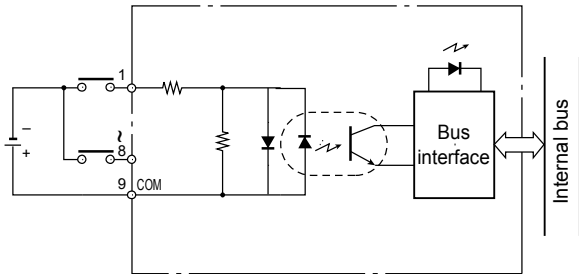

F3XD32-3F
F3XD32-4F
F3XD32-5F

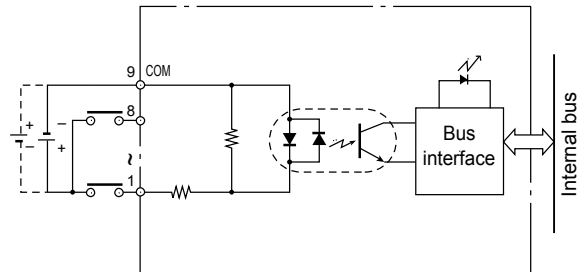

F3XD64-3F
F3XD64-4F

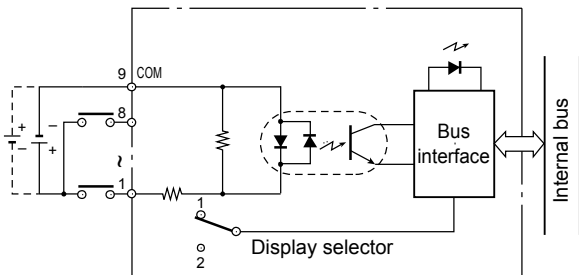

F3XD64-6M

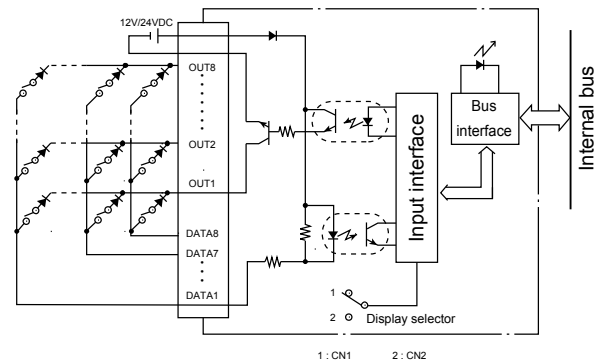

External Connection Diagram

F3XA08-1N
F3XA08-2N

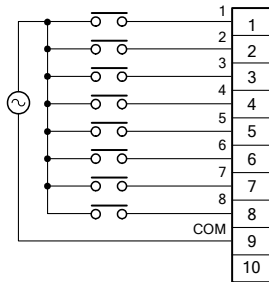

Note: Viewed from the front of the module.

F3XC08-0C

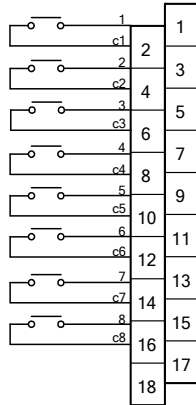

Note: Viewed from the front of the module.

F3XC08-0N

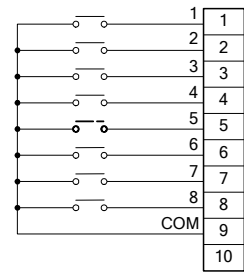

Note: Viewed from the front of the module.

F3XA16-1N

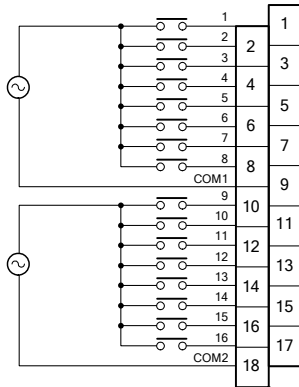

Note: Viewed from the front of the module.

F3XD08-6F

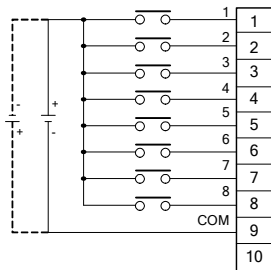

Note: Viewed from the front of the module.

F3XD16-3F
F3XD16-4F

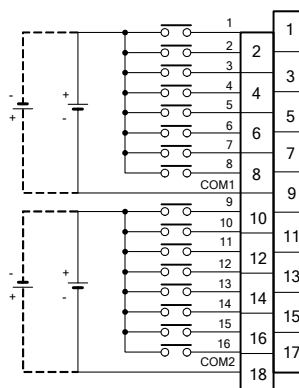

Note: Viewed from the front of the module.

F3XD16-3H

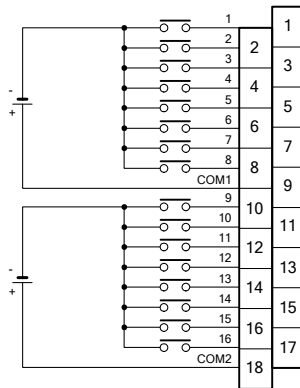

Note: Viewed from the front of the module.

F3XD32-3F
F3XD32-4F
F3XD32-5F

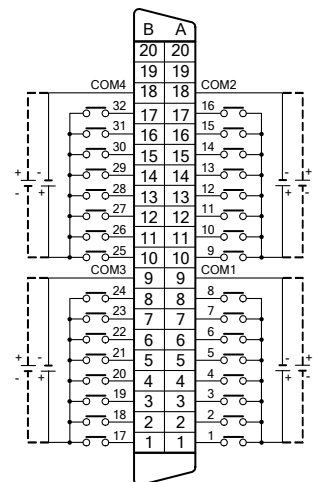

Note: Viewed from the front of the module.

F3XD64-3F
F3XD64-4F

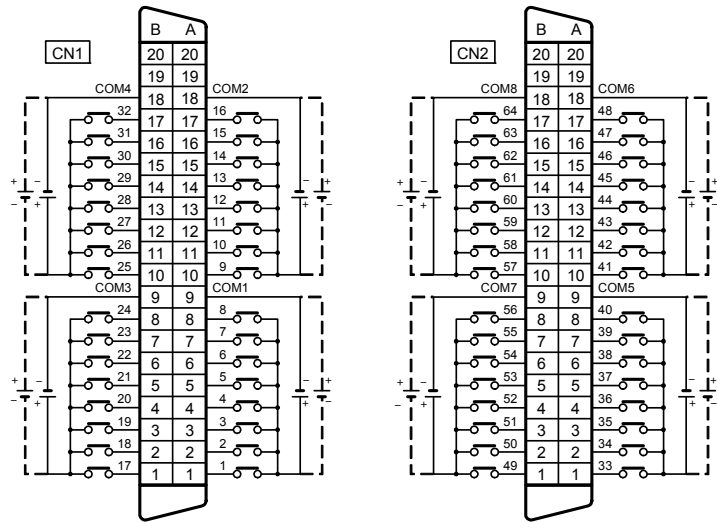

FA020528.VSD

Note: Viewed from the front of the module.

F3XD64-6M

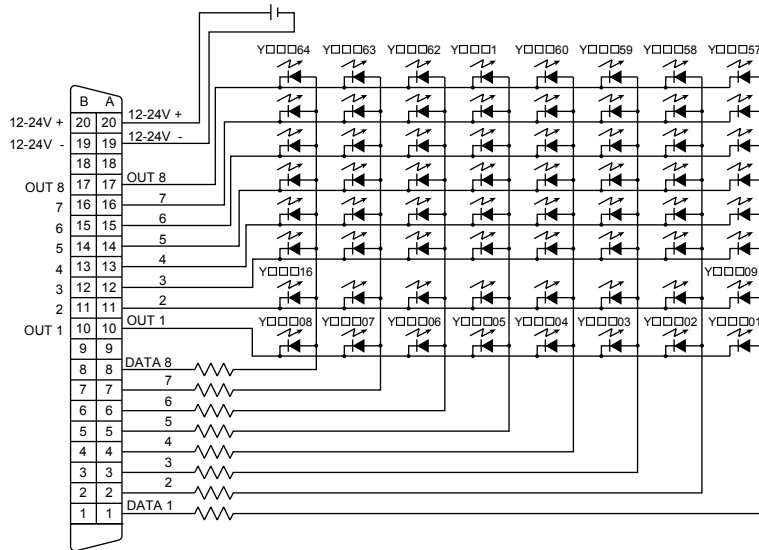

Note: Viewed from the front side of the module.

FA020588.VSD

■ Terminal Arrangement

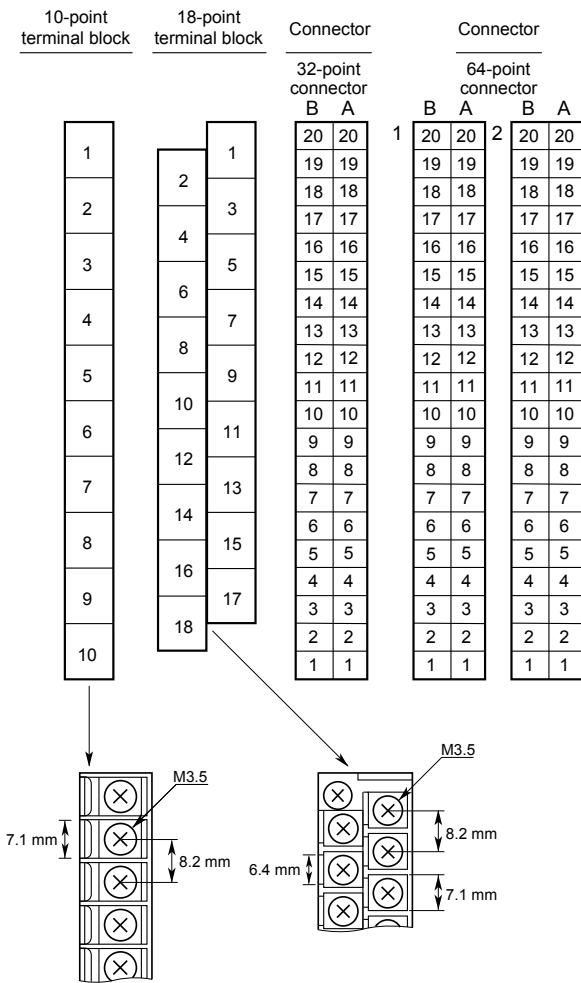

■ External Connection Method

	Terminal Block Type	Connector Type		
		0.26 mm ² max.	0.08 - 0.20 mm ²	Flat cable, 1.27 mm pitch, 0.08 mm ²
Applicable conductor size	0.33 - 0.82 mm ²	0.26 mm ² max.	0.08 - 0.20 mm ²	Flat cable, 1.27 mm pitch, 0.08 mm ²
Wire connection method	Solderless	Soldered	Solderless	Solderless
Rated wire temperature	75°C min.			
Wire Material	Copper			
Solderless terminal	Solderless terminal	For 3.5 mm terminals	—	
	Crimping torque	0.8 N·m (8 kgf·cm, 6.9 lbf·in)	—	
	Applicable solderless terminal	Example: Japan Solderless Terminal Mfg Co., Ltd.: V1.25-M3 Nippon Tanshi Co., Ltd.: RAV1.25-3.5	—	

■ Applicable External Connectors

Connection Method	Applicable Connector
Soldered type	Fujitsu : FCN-361J040-AU connector FCN-360C040-B connector cover
Solderless type	Fujitsu : FCN-363J040 housing FCN-363J-AU contact FCN-360C040-B connector cover
Solderless type	Fujitsu : FCN-367J040-AU/FW

Operating Environment

There is no restriction on the type of CPU modules that can be used with this module.

Environment Specifications

Item	Specifications
Surrounding air temperature range	Operating : 0 to 55°C
	Storage : -20°C to 75°C
Surrounding humidity range	Operating : 10 to 90% RH (non-condensing)
	Storage : 10 to 90% RH (non-condensing)
Surrounding atmosphere	Must be free of corrosive gases, flammable gases or heavy dust.

Model and Suffix Codes

Model	Suffix code	Style code	Option code	Description
F3XA08	-1N	100-120 V AC input, 8 points
F3XA08	-2N	200-240 V AC input, 8 points
F3XA16	-1N	100-120 V AC input, 16 points
F3XC08	-0C	No-voltage contact, 8 points (with separate commons)
F3XC08	-0N	No-voltage contact, 8 points
F3XD08	-6F	DC input sink/source, 12-24 V DC, 8 points
F3XD16	-3F	DC input sink/source, 24 V DC, 16 points
F3XD16	-4F	DC input sink/source, 12 V DC, 16 points
F3XD32	-3F	DC input sink/source, 24 V DC, 32 points*
F3XD32	-4F	DC input sink/source, 12 V DC, 32 points*
F3XD32	-5F	DC input sink/source, 5 V DC, 32 points*
F3XD64	-3F	DC input sink/source, 24 V DC, 64 points*
F3XD64	-4F	DC input sink/source, 12 V DC, 64 points*
F3XD64	-6M	DC input matrix scan 12-24 V DC, 64 points*
F3XD16	-3H	DC input (sink, +common), 24 V DC, 16 points (Quick response type)

*: See the section on spare parts in FA-M3 Range-free Multi-controller (GS 34M06A01-01E) for information on connectors.

External Dimensions

F3XA08, F3XC08-0N, F3XD08

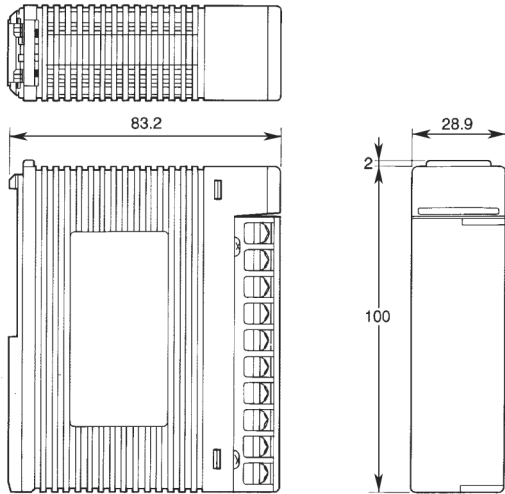

F3XC08-0C, F3XD16

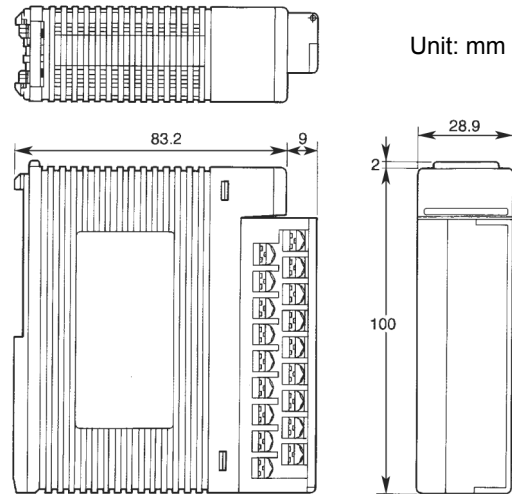

Unit: mm

F3XA16

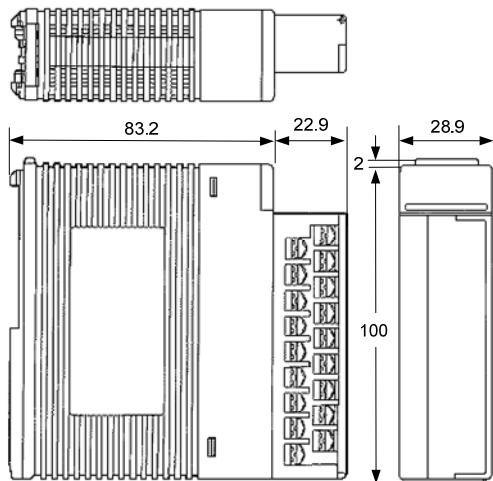

F3XD32

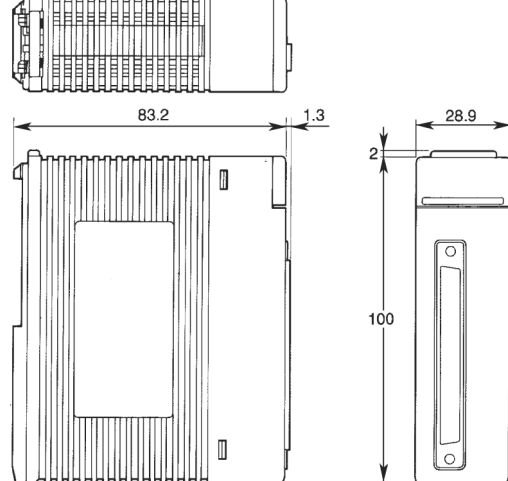

F3XD64-3F, F3XD64-4F

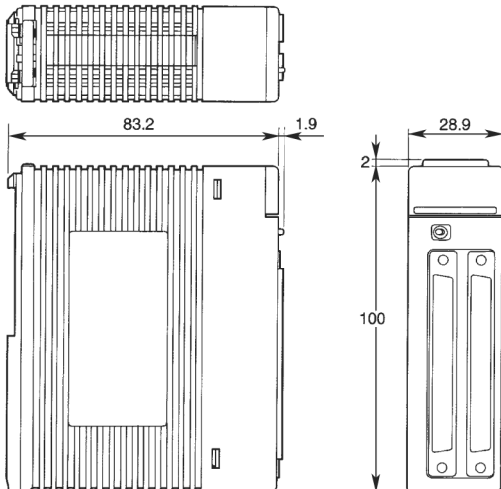

F3XD64-6M

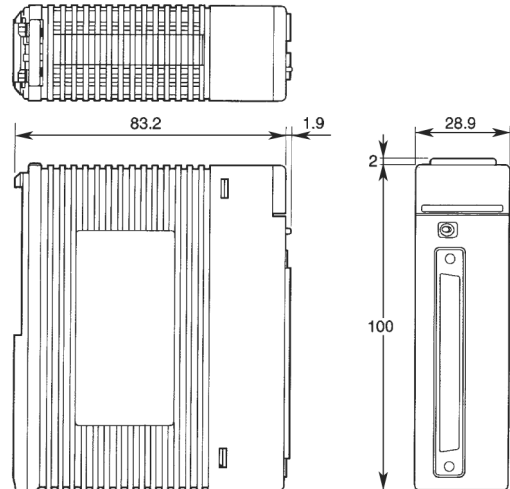

General Specifications

FA-M3

F3YD04, F3YA08, F3YC08, F3YC16, F3YD08, F3YD14, F3YD32 and F3YD64 Output Modules

General

The output modules for the FA-M3 are listed below. Select the most appropriate modules according to your applications.

- F3YD04-7N Transistor output module
- F3YA08-2N TRIAC output module
- F3YC08-0C Relay output module
- F3YC08-0N Relay output module
- F3YC16-0N Relay output module
- F3YD08-6A Transistor output module
- F3YD08-6B Transistor output module
- F3YD08-7A Transistor output module
- F3YD14-5A Transistor output module
- F3YD14-5B Transistor output module
- F3YD32-1T TTL output module
- F3YD64-1M Transistor output module

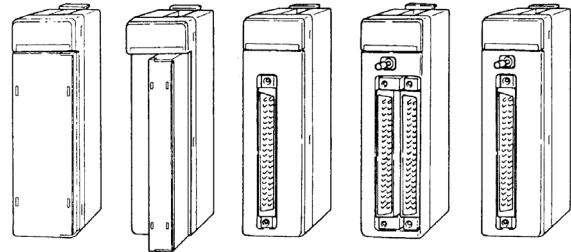

Components and Functions

The output modules are divided into terminal block and connector types as given below.

Terminal block

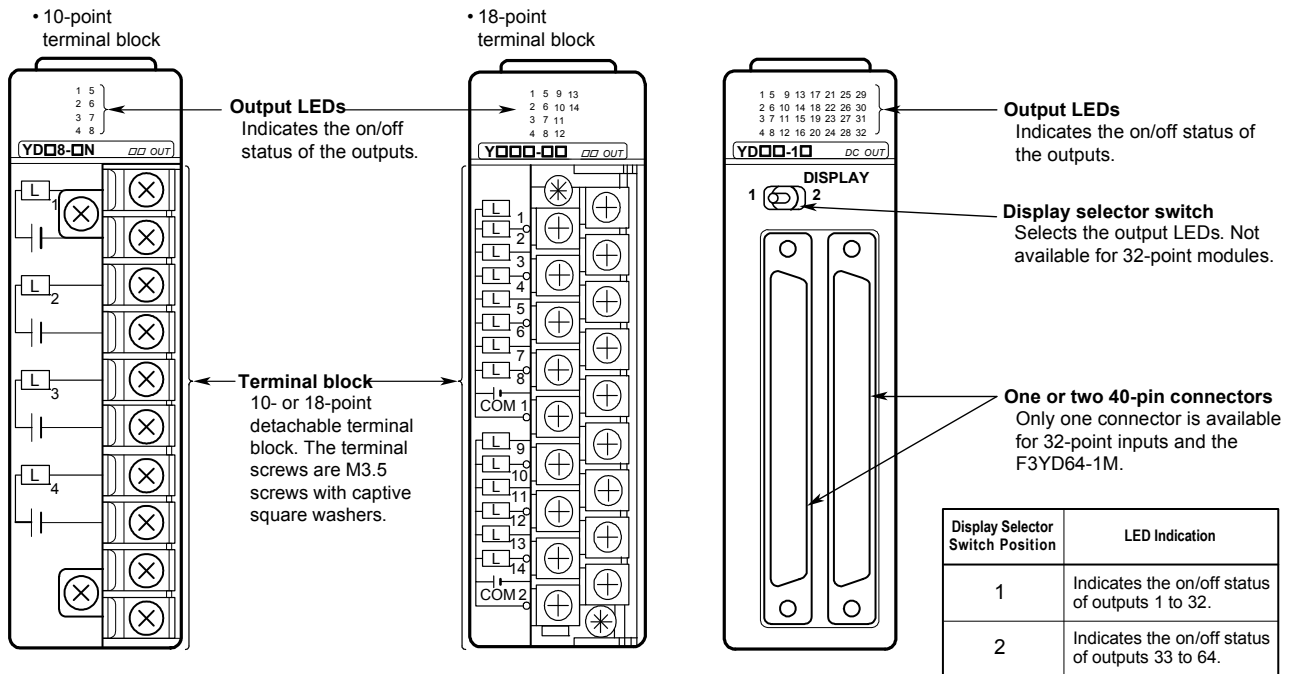

Specifications

Model	Output Type	Number of Outputs	Points/ Common	Isolation Method	Rated Load Voltage	Maximum load current	Response Time	
							OFF→ON	ON→OFF
F3YD04-7N	Transistor contact	4	All points independent	Photocoupler Isolation	24 V DC	2 A/point	5 ms max.	3 ms max.
F3YA08-2N	TRIAC contact	8	8 points/ common	Photocoupler Isolation	100—240 V AC	1 A/point (0 - 40°C) 0.7 A/point (40 - 55°C) 3 A/common	1 ms max.	1/2 cycle +1 ms max.
F3YC08-0C ⁴	Relay contact	8	All points independent	Mechanical Isolation	DC 5-24 V AC 100-240 V	2 A/point	10 ms max.	10 ms max.
F3YC08-0N ⁴	Relay contact	8	8 points/ common	Mechanical Isolation		2 A/point 8 A/common	10 ms max.	10 ms max.
F3YD08-6 A	Transistor contact (sink type)	8	8 points/ common	Photocoupler Isolation	12—24 V DC	1 A/point 4 A/common	1 ms max.	1 ms max.
F3YD08-6B	Transistor contact (source type)	8	8 points/ common	Photocoupler Isolation	12—24 V DC	1 A/point 4 A/common	1 ms max.	1 ms max.
F3YD08-7A	Transistor contact (sink type)	8	8 points/ common	Photocoupler Isolation	12—24 V DC	2 A/point 8 A/common	1 ms max.	1 ms max.
F3YD14-5A	Transistor contact (sink type)	14	8 points/ common 6 points/ common	Photocoupler Isolation	12—24 V DC	0.5 A/point 2 A/common	1 ms max.	1 ms max.
F3YD14-5B	Transistor contact (source type)	14		Photocoupler Isolation	12—24 V DC	0.5 A/point 2 A/common	1 ms max.	1 ms max.
F3YC16-0N ⁴	Relay contact	16	8 points/ common	Mechanical Isolation	DC 5-24 V AC 100-240 V	2 A/point 8 A/common	10 ms max.	10 ms max.
F3YD32-1T	Transistor contact (TTL output)	32	8 points/ common	Photocoupler Isolation	5 V DC	16 mA/point 128 mA/common	1 ms max.	1 ms max.
F3YD64-1M	Transistor contact (matrix scan)	64	8 x 8 matrix	Photocoupler Isolation	12—24 V DC	0.1 A	16 ms max.	16 ms max.

Model	Life	ON voltage	Off-time Leakage Current	Surge Protector	CPU Error Output ³ HOLD/RESET	Current Consumption	External Power Supply	External Connection	Weight	
F3YD04-7N	—	0.5 V DC max.	0.1 mA max.	Zener diode	When a sequence CPU is used: Initial value: RESET All module outputs can be set collectively ² .	85 mA (5 V DC)	Not required	10 -point terminal block M3.5 screw	140 g	
F3Y A08-2N	—	1.5 V AC max.	3 mA max.	CR absorber Varistor		130 mA (5 V DC)	Not required		150 g	
F3YC08-0C ⁴	Mechanical: 20,000,000 operations or more Electrical: 100,000 operations or more	—	—	None		205 mA (5 V DC)	Not required	18 -point terminal block M3.5 screw	180 g	
F3YC08-0N ⁴		—	—	None		205 mA (5 V DC)	Not required	10 -point terminal block M3.5 screw	160 g	
F3YD08-6A	—	0.5 V DC max.	0.1 mA max.	Active clamp		60 mA (5 V DC)	12—24 V DC 10 mA	10 -point terminal block M3.5 screw	130 g	
F3YD08-6B	—	0.5 V DC max.	0.1 mA max.	Active clamp		60 mA (5 V DC)	12—24 V DC 10 mA	10 -point terminal block M3.5 screw	130 g	
F3YD08-7A	—	0.5 V DC max.	0.1 mA max.	Active clamp		80 mA (5 V DC)	12—24 V DC 10 mA	10 -point terminal block M3.5 screw	130g	
F3YD14-5A	—	0.5 V DC max.	0.1 mA max.	Active clamp		When a BASIC CPU is used:	120 mA (5 V DC)	12—24 V DC 20 mA	18 -point terminal block M3.5 screw	160 g
F3YD14-5B	—	0.5 V DC max.	0.1 mA max.	Active clamp		No setting function; Always set to HOLD.	120 mA (5 V DC)	12—24 V DC 20 mA	18 -point terminal block M3.5 screw	160 g
F3YC16-0N ⁴	Mechanical: 20,000,000 operations or more Electrical: 100,000 operations or more	—	—	None		380 mA (5 V DC)	Not required	18 -point terminal block M3.5 screw	220 g	
F3YD32-1T		—	—	—	Zener diode	210 mA (5 V DC)	5 V DC 60 mA	One 40-pin connector	110 g	
F3YD64-1M	—	1.5 V DC max.	0.1 mA max.	Zener diode	125 mA (5 V DC)	12—24 V DC 40 mA	One 40-pin connector	110 g		

Note: See external dimensions for dimensions of the modules.

*1: When F3SP28, F3SP38, F3SP5x, F3SP6x or F3SP7x is used, the output for CPU fatal errors can be set either to HOLD or RESET.

*2 When F3SP28, F3SP38, F3SP5x, F3SP6x or F3SP7x is used, all points can be specified in 16-point units.

*3 For details on the module behavior when the CPU fails, see the "Severity of Failures and LED Display" in the "FA-M3 Range-free Multi-controller (GS 34M06A01-01E)".

*4 The relays in the relay output modules are not of hermetically sealed type. Dust or corrosive gases in the installation environment will adversely affect the service life of the relays. Relays that are switched on and off in an atmosphere containing silicone gases from silicone-based materials may suffer from poor electrical contact due to SiO₂ (silicon dioxide) formed and deposited on the surfaces of their contacts. Risks of bad contact due to silicon gases are especially high under load conditions below 24 VDC and 500 mA. In such environments, we recommend the use of transistor output modules or other modules employing semiconductor elements instead.

Internal Circuit Diagram

F3YD04-7N Transistor output module

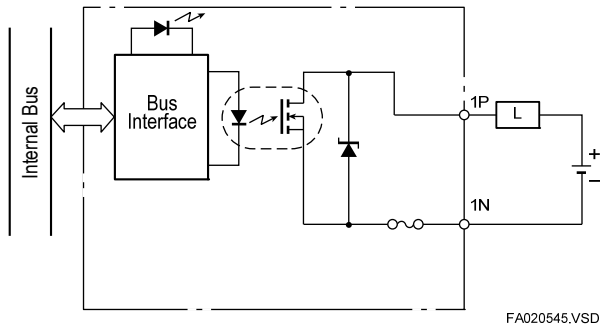

F3YA08-2N TRIAC output module

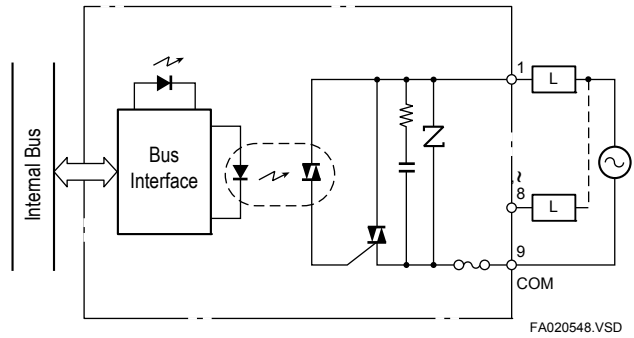

F3YD08-7A Transistor output module
F3YD08-6A Transistor output module
F3YD14-5A Transistor output module

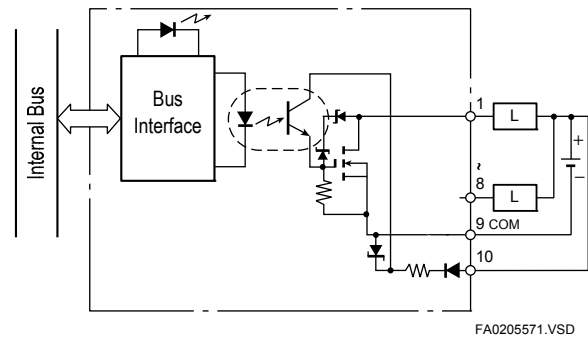

F3YD08-6B Transistor output module
F3YD14-5B Transistor output module

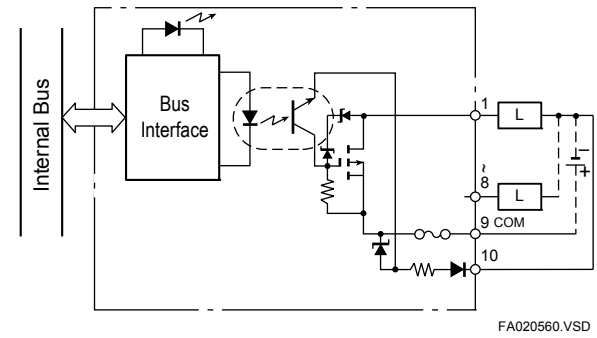

F3YC08-0C Relay output module

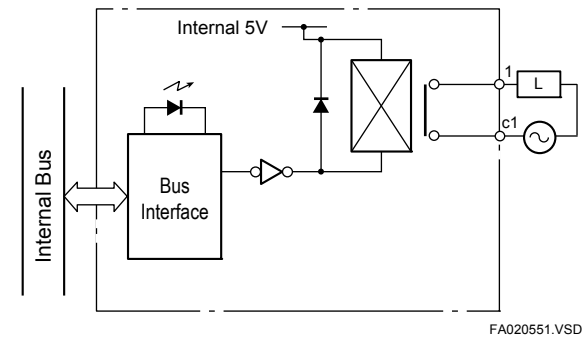

F3YC08-0N Relay output module
F3YC16-0N Relay output module

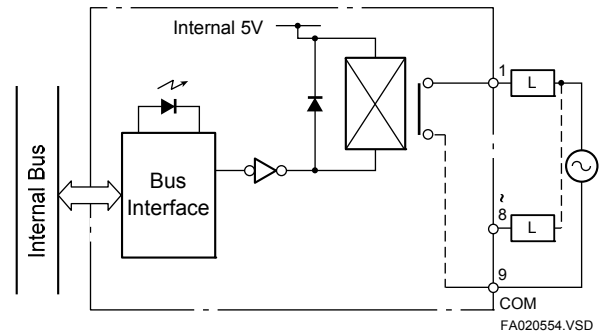

F3YD32-1T TTL output module

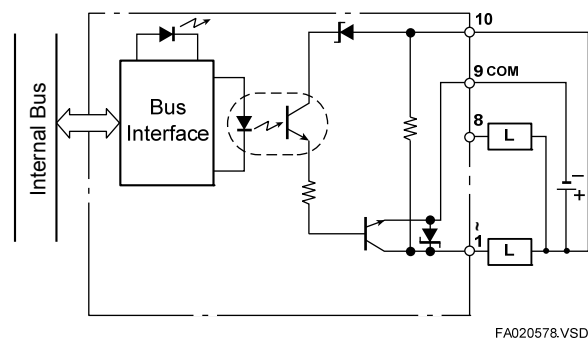

F3YD64-1M Transistor output module

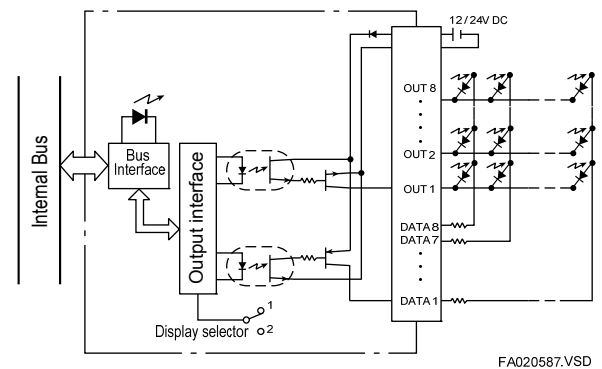

External Connection Diagram

F3YD04-7N Transistor output module

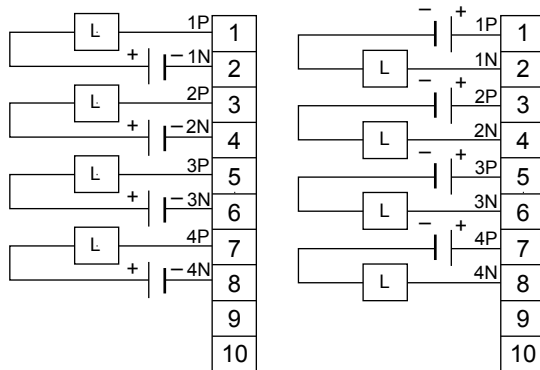

Note: Viewed from the front of the module.

F3YA08-2N TRIAC output module

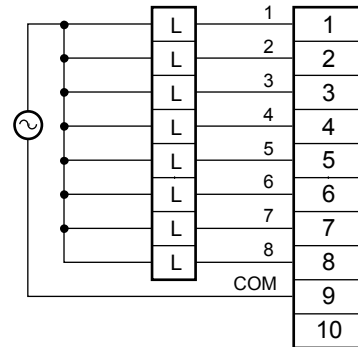

Note: Viewed from the front of the module.

F3YC08-0C Relay output module

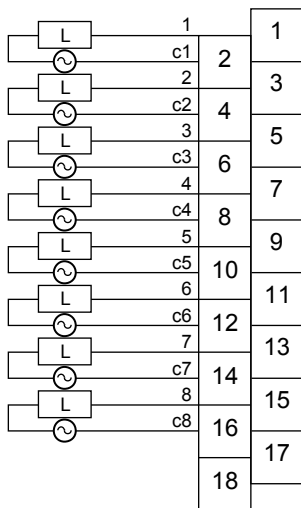

Note: Viewed from the front of the module.

F3YC08-0N Relay output module

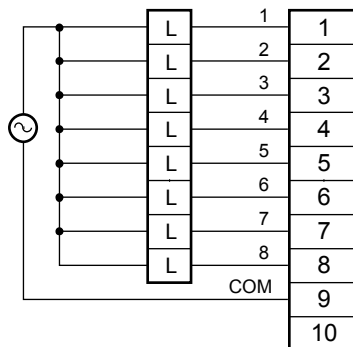

Note: Viewed from the front of the module.

F3YC16-0N Relay output module

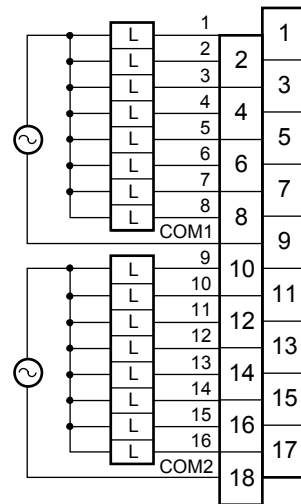

Note: Viewed from the front of the module.

F3YD08-6A Transistor output module
F3YD08-7A Transistor output module

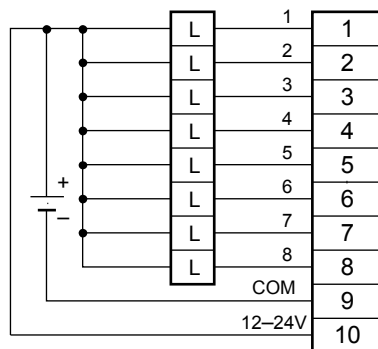

Note: Viewed from the front of the module.

F3YD08-6B Transistor output module

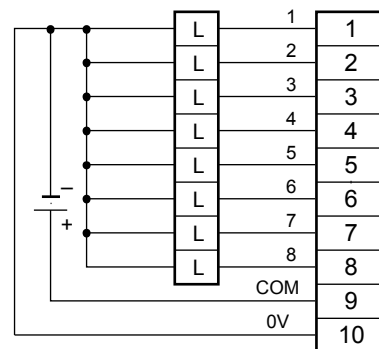

Note: Viewed from the front of the module.

F3YD14-5A Transistor output module

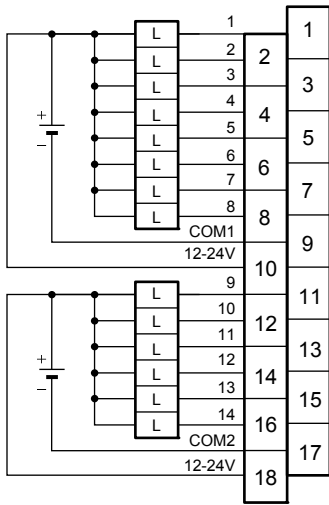

FA020564.VSD

Note: Viewed from the front side of the module.

F3YD14-5B Transistor output module

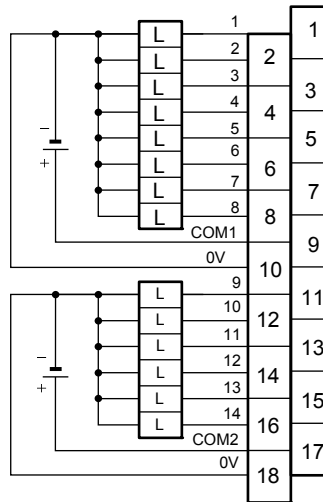

FA020567.VSD

Note: Viewed from the front side of the module.

F3YD32-1T TTL output module

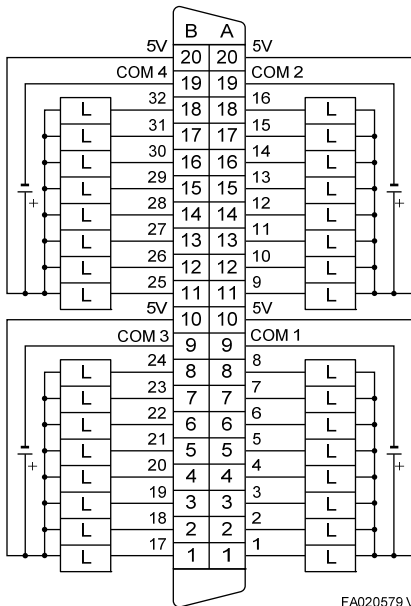

FA020579.VSD

Note: Viewed from the front side of the module.

F3YD64-1M Transistor output module

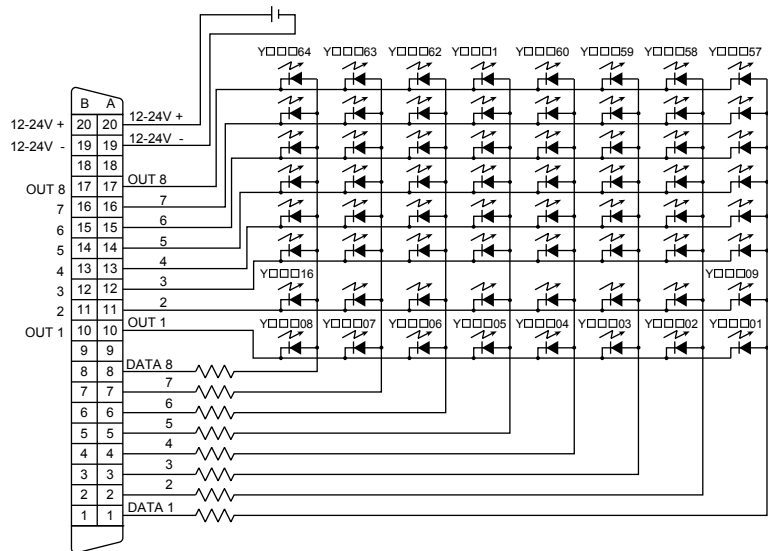

Note: Viewed from the front side of the module.

FA020588.VSD

■ Terminal Arrangement

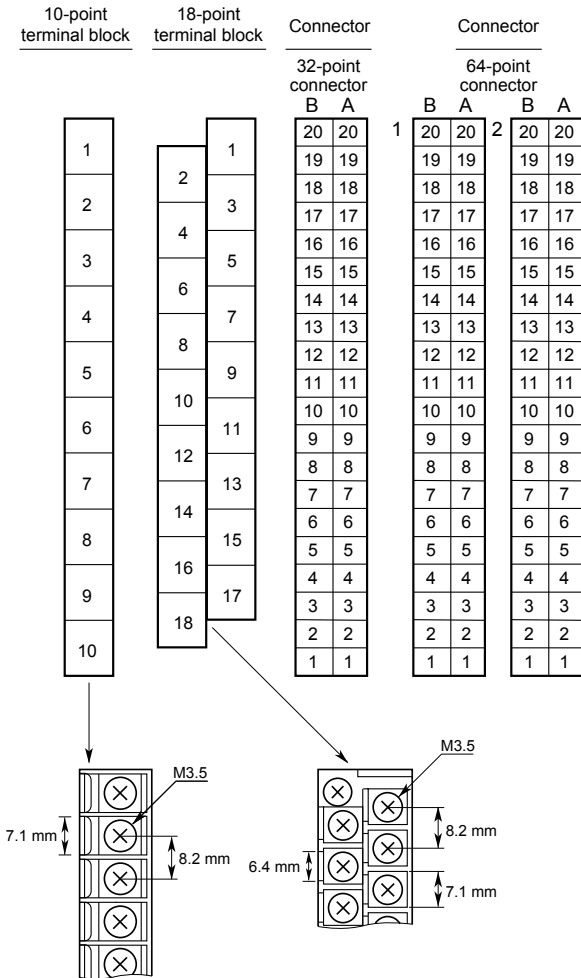

■ External Connection Method

		Terminal Block Type	Connector Type		
Applicable conductor size	0.33 - 0.82 mm ²	0.26 mm ² max.	0.08 - 0.20 mm ²	Flat cable, 1.27 mm pitch, 0.08 mm ²	
Wire connection method	Solderless	Soldered	Solderless	Solderless	
Rated wire temperature	75°C min.				
Wire Material	Copper				
Solderless terminal	Solderless terminal	For 3.5 mm terminals	—		
	Crimping torque	0.8 N·m {8 kgf·cm, 6.9 lbf·in}	—		
	Applicable solderless terminal	Example: Japan Solderless Terminal Mfg Co., Ltd.: V1.25-M3 Nippon Tanshi Co., Ltd.: RAV1.25-3.5	—		

■ Applicable External Connectors

Connection Method	Applicable Connector
Soldered type	Fujitsu : FCN-361J040-AU connector FCN-360C040-B connector cover
Solderless type	Fujitsu : FCN-363J040 housing FCN-363J-AU contact FCN-360C040-B connector cover
Solderless type	Fujitsu : FCN-367J040-AU/FW

Operating Environment

There is no restriction on the type of CPU modules that can be used with this module.

Environment Specifications

Item	Specifications
Surrounding air temperature range	Operating : 0 to 55°C
	Storage : -20°C to 75°C
Surrounding humidity range	Operating : 10 to 90% RH (non-condensing)
	Storage : 10 to 90% RH (non-condensing)
Surrounding atmosphere	Must be free of corrosive gases, flammable gases or heavy dust.

Model and Suffix Codes

Model	Suffix code	Style code	Option code	Description
F3YD04	-7N	Transistor output, 24 V DC 2 A, 4 points, all points independent
F3YA08	-2N	TRIAC output, 100–240 V AC 1 A, 8 points
F3YC08	-0C	Relay output, 24 V DC, 100–240 V AC 2 A, 8 points, all points independent
F3YC08	-0N	Relay output, 24 V DC, 100–240 V AC 2 A, 8 points
F3YC16	-0N	Relay output, 24 V DC, 100–240 V AC 2 A, 16 points
F3YD08	-6A	Transistor output (sink type), 12–24 V DC 1 A, 8 points
F3YD08	-6B	Transistor output (source type), 12–24 V DC 1 A, 8 points
F3YD08	-7A	Transistor output (sink type), 12–24 V DC 2 A, 8 points
F3YD14	-5A	Transistor output (sink type), 12–24 V DC 0.5 A, 14 points
F3YD14	-5B	Transistor output (source type), 12–24 V DC 0.5 A, 14 points
F3YD32	-1T	TTL output, 5 V DC, 32 points*
F3YD64	-1M	Transistor output (matrix scan), 12–24 V DC 0.1 A, 64 points

*: See the section on spare parts in the FA-M3 Range-free Multi-controller (GS 34M06A01-01E) for information on connectors.

External Dimensions

F3YA08, F3YD04, F3YC08-0N, F3YD08

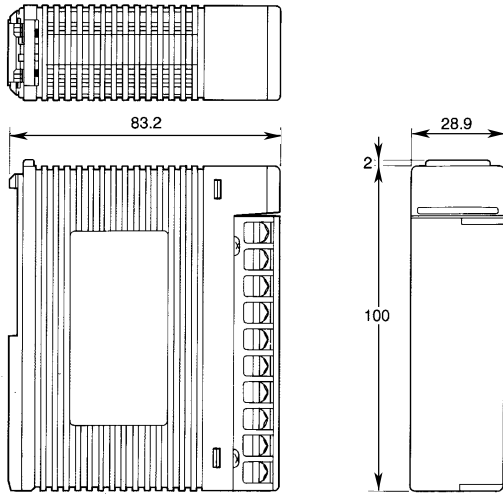

F3YD14, F3YC08-0C, F3YC16

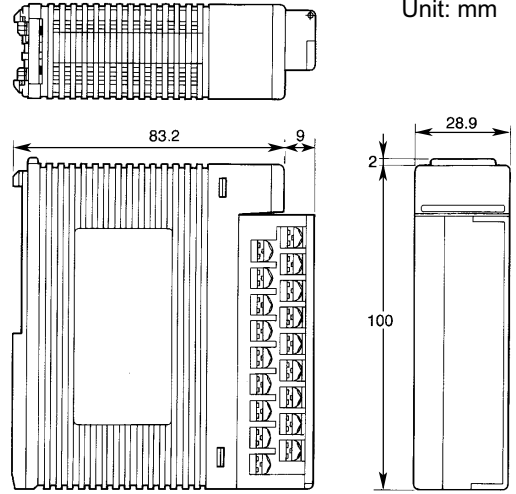

F3YD32

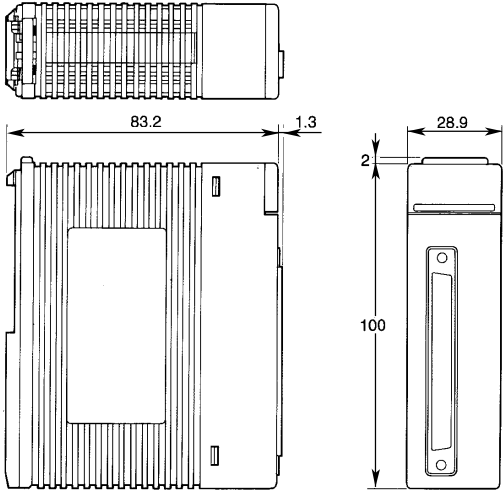

F3YD64-1M

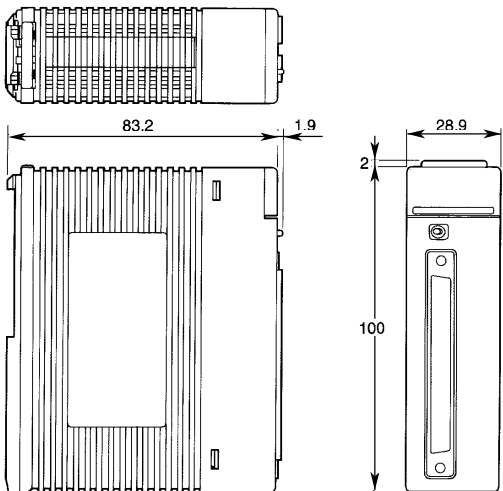

General Specifications

F3YD32-1H High-Speed Transistor Output Modules (sink type with short-circuit protector)

FA-M3

General

F3YD32-1H is a high-speed transistor output module with 32 outputs.

Features

- Built-in protection against output short-circuit
- High speed response of 0.1 ms max.
- Support for multi-channel pulse output applications

Specifications

Item	F3YD32-1H	
Output type	Transistor contact (sink type)	
Number of points	32	
Common line type	8 points/common	
Isolation method	Photocoupler isolation	
Withstanding voltage	1500 V AC for one minute between the group of terminals for external connection and the internal circuit	
Rated load voltage (Operating voltage range)	12 to 24 V DC (10.2 to 26.4 V DC)	
Maximum load current	0.1 A/point 0.5 A/common	
Response time	OFF→ON ON→OFF	
ON voltage	0.5 V DC max.	
Off-time leak current	0.1 mA max.	
Service life	Mechanical —	
Protectors *1	Short-circuit	Limits short-circuit current.
	Overheat	Shuts off output when overheat is detected.
Surge Protector *2	Active clamp	
Fuse	None	
Current consumption	165 mA (5 V DC)	
Output display *3	LED (Lit when output is on)	
Output status when program stops *4 HOLD/RESET	When a sequence CPU is used: Initial value: RESET All module outputs can be set collectively. *5 When a BASIC CPU is used: No setting function; always set to HOLD	
External power supply	12 to 24 V DC, 30 mA	
External connection	One 40-pin connector	
Weight	110 g	

- *1: Operation of the protection circuitry:
- If short-circuit occurs, the ON voltage increases and the short-circuit current is limited within the range 1-3 A.
 - If the short-circuit condition is removed, normal operation resumes.
 - If the short-circuit condition persists, the short-circuit current may cause the temperature of the output element to reach approx. 160°C, triggering the overheat protector to shut down the output.
 - If the temperature of the overheated output element then drops by approximately 10°C, normal operation resumes.
 - The overheat protector will not be triggered if the module is operated normally within its specifications with no short-circuit condition.
 - Both the short-circuit protector and overheat protector are designed to control outputs individually. Under some short-circuit conditions, however, the overheat protector may shut down not only its associated output but also other outputs.
 - Short-circuit and overheat protectors are designed to protect the output element against short-term short-circuit. Never leave the module in prolonged short-circuit condition. Otherwise, the module enclosure may deteriorate or the PCB may be discolored.

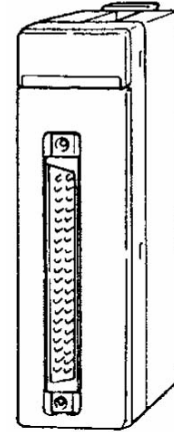

- Ensure that the polarity of the external power supply is correct. Otherwise, a short-circuit condition may damage an output element, with smoldering and scattering of broken pieces.
- Ensure that the polarity of the external power supply is correct. Otherwise, a short-circuit condition may damage an output element, and cause smoldering and scattering of chips. Beware that wrongly connecting a connector wired for F3XD32 or F3XD64 to the module may disable the protectors and damage internal elements.
- *2: If an inductive load, such as a relay, is to be connected, a surge protector is also required on the load side. Connect a surge protector or a diode across the load nearby so that the module output terminal voltage will not exceed the specified operating load voltage range.
- *3: The contact operation of the output block of the circuit and the LED display operate independently and thus may be inconsistent in the event of an error.
- *4: For details on the module behavior when the CPU fails, see the Severity of Failures and LED Display" in the FA-M3 Range-free Multi-controller (GS 34M06A01-01E).
- *5: When F3SP28, F3SP38, F3SP5□, F3SP6□ or F3SP7□ is used, all points can be specified in 16-point units.

Components and Functions

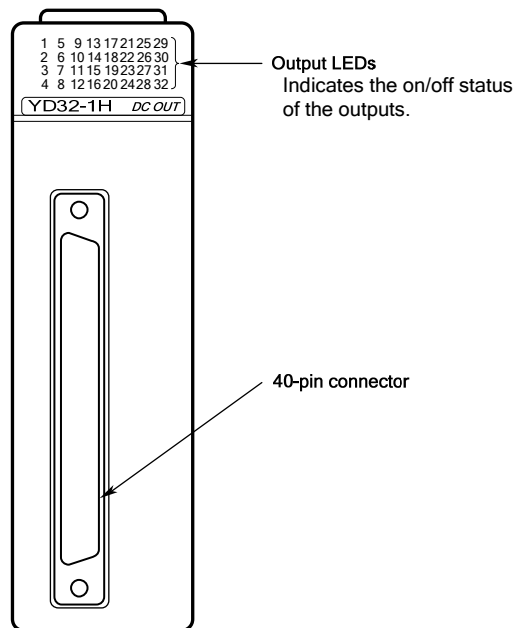

External Connection Diagram

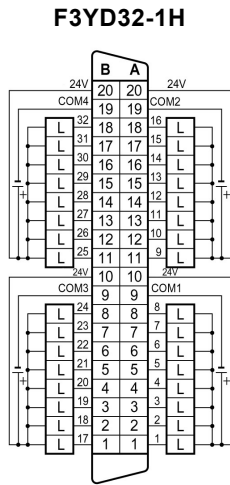

Note: Viewed from the front of the module.

Terminal Arrangement

B	A
20	20
19	19
18	18
17	17
16	16
15	15
14	14
13	13
12	12
11	11
10	10
9	9
8	8
7	7
6	6
5	5
4	4
3	3
2	2
1	1

Internal Circuit Diagram

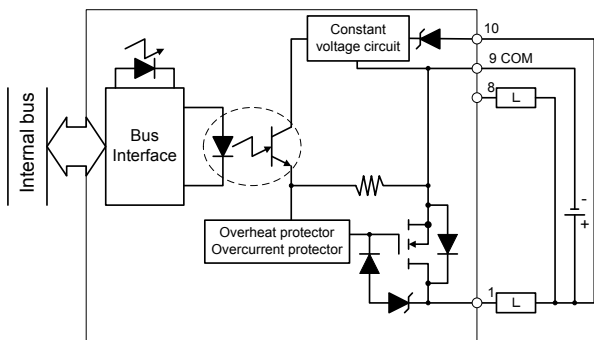

External Connection Method

Applicable conductor size	0.26 mm ² max.	0.08-0.20 mm ²	Flat cable, 1.27 mm pitch, 0.08 mm ²
Wire connection method	Soldered	Solderless	Solderless
Rated wire temperature	75°C min.		
Wire material	Copper		

Applicable External Connectors

Connection Method	Applicable Connector
Soldered type	Fujitsu: FCN-361J040-AU connector FCN-360C040-B connector cover
Solderless type	Fujitsu: FCN-363J040 connector FCN-363J-AU contact FCN-360C040-B connector cover
Solderless type	Fujitsu: FCN-367J040-AU/FW

Operating Environment

This module is compatible with all CPU module types.

Environment Specifications

Item	Specifications
Surrounding air temperature range	Operating : 0 to 55°C
	Storage : -20°C to 75°C
Surrounding humidity range	Operating : 10 to 90% RH (non-condensing)
	Storage : 10 to 90% RH (non-condensing)
Surrounding atmosphere	Must be free of corrosive gases, flammable gases or heavy dust.

Model and Suffix Codes

Model	Suffix Code	Style Code	Option Code	Description
F3YD32	-1H	Transistor output, 32 points (high-speed output with short-circuit protector)

External Dimensions

F3YD32-1H

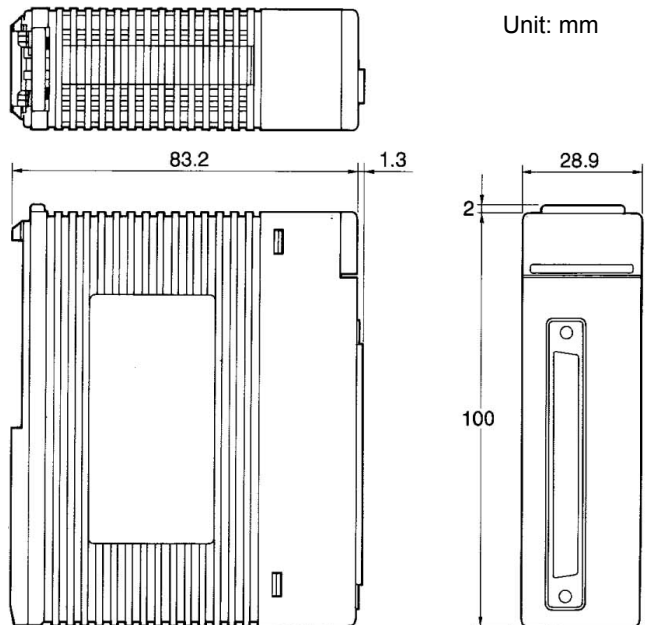

Unit: mm

General Specifications

F3YD32-1P, F3YD64-1P Transistor Output Modules (sink type with short-circuit protector)

FA-M3

General

F3YD32-1P and F3YD64-1P are 32- and 64-point transistor output modules respectively.

Features

- The modules have built-in protection against output short-circuit.

Specifications

Model		F3YD32-1P	F3YD64-1P
Output type		Transistor contact (sink type)	
Number of points		32	64
Common line type		8 points/common	
Isolation method		Photocoupler isolation	
Withstanding voltage		1500 V AC for one minute between the group of terminals for external connection and the internal circuit	
Rated load voltage (Operating voltage range)		12 to 24 V DC (10.2 to 26.4 V DC)	
Maximum load current		0.1 A/point 0.5 A/common	0.1 A/point 0.4 A/common
Response time	OFF→ON	1 ms max.	
	ON→OFF	1 ms max.	
ON voltage		0.5 V DC max.	
Off-time leak current		0.1 mA max.	
Service life	Mechanical	—	
Protectors *1	Short-circuit	Controlled short-circuit current	
	Overheat	Output shutdown	
Surge Protector *2		Active clamp circuit	
Fuse		None	
Current consumption		160 mA (5 V DC)	275 mA (5 V DC)
Output display *3		LED (Lit when output is on)	LED (Lit when outputs are turned on for a switched LED group)
Output status when program stops *4 HOLD/RESET		When a sequence CPU is used: Default: RESET Can be set globally on a module-by-module basis *5 When a BASIC CPU is used: No setting function; The status is always HOLD	
External power supply		12 to 24 V DC 55 mA	12 to 24 V DC 95 mA
External connection		One 40-pin connector	Two 40-pin connectors
Weight		110 g	130 g

- *1: Operation of the protection circuitry:
- If short-circuit occurs, the ON voltage increases and the short-circuit current is limited within the range 1-3 A.
 - If the short-circuit condition is removed, normal operation resumes.
 - If the short-circuit condition persists, the short-circuit current may cause the temperature of the output element to reach approx. 160°C, triggering the overheat protector to shut down the output.
 - If the temperature of the overheated output element then drops by about 10°C, normal operation resumes.
 - The overheat protector will not be triggered if the module is operated normally within its specifications with no short-circuit condition.
 - Both the short-circuit protector and overheat protector are designed to control outputs individually. Under some short-circuit conditions, however, the overheat protector may shut down not only its associated output but also other outputs.

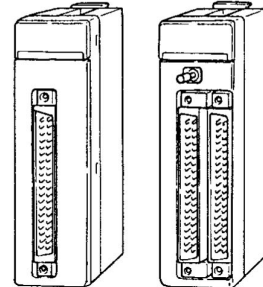

- Short-circuit and overheat protectors are designed to protect the output element against short-term short-circuit. Never leave the module in prolonged short-circuit condition. Otherwise, the module enclosure may deteriorate or the PCB may be discolored.
- Ensure that the polarity of the external power supply is correct. Otherwise, a short-circuit condition may damage an output element, and cause smoldering and scattering of chips. Beware that wrongly connecting a connector wired for F3XD32 or F3XD64 to the module may disable the protectors and damage internal elements.
- *2: If an inductive load, such as a relay, is to be connected, a surge protector is also required on the load side. Connect a surge protector or a diode across the load nearby so that the module output terminal voltage will not exceed the specified operating load voltage range.
- *3: The contact operation of the output block of the circuit and the LED display operate independently and thus may be inconsistent in the event of an error.
- *4: For details on the module behavior when the CPU fails, see the Severity of Failures and LED Display* in the FA-M3 Range-free Multi-controller (GS 34M06A01-01E).
- *5: When F3SP28, F3SP38, F3SP5□, F3SP6□ or F3SP7□ is used, all points can be specified in 16-point units.

Components and Functions

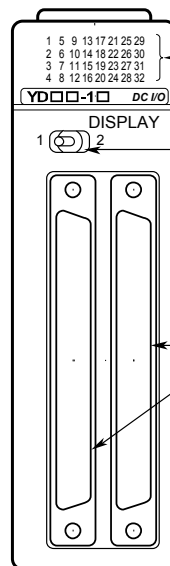

Output LEDs

Indicates the on/off status of the outputs.

Display Selector Switch

Switches display of output LEDs. Not present on 32-point modules.

One or two 40-pin connectors

32-point modules have only one connector.

Display Selector Switch Position	Output LEDs 1-32
1	Indicates on/off statuses of outputs 1 to 32.
2	Indicates on/off statuses of outputs 33 to 64.

External Connection Diagram

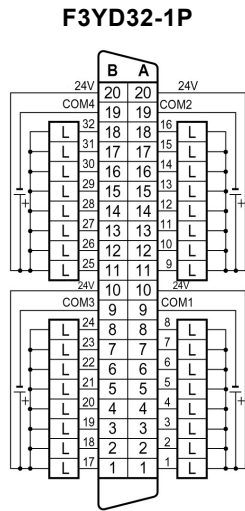

Note: Viewed from the front of the module.

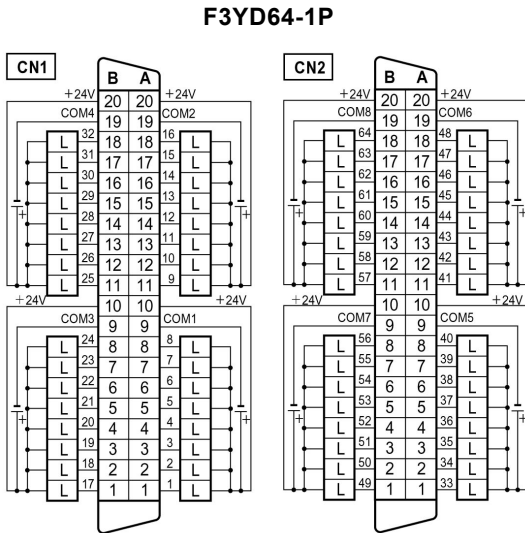

Note: Viewed from the front of the module.

Terminal Arrangement

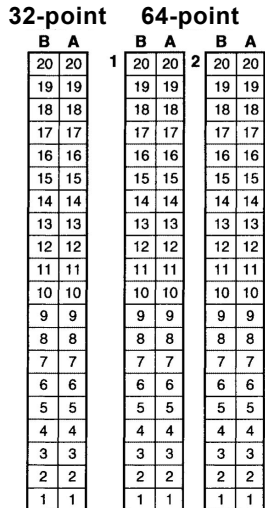

Internal Circuit Diagram

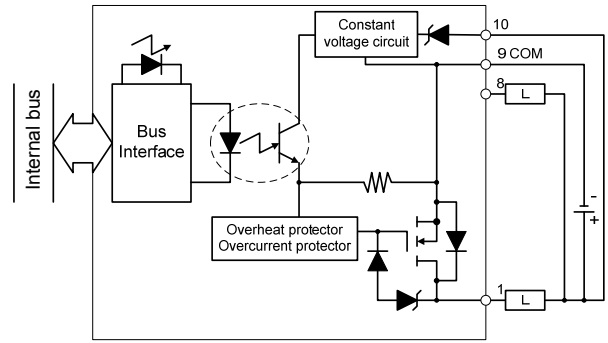

External Connection Method

Applicable conductor size	0.26 mm ² max.	0.08-0.20 mm ²	Flat cable, 1.27 mm pitch, 0.08 mm ²
Wire connection method	Soldered	Solderless	Solderless
Rated wire temperature	75°C min.		
Wire material	Copper		

Applicable External Connectors

Connection Method	Applicable Connector
Soldered type	Fujitsu: FCN-361J040-AU connector FCN-360C040-B connector cover
Solderless type	Fujitsu: FCN-363J040 connector FCN-363J-AU contact FCN-360C040-B connector cover
Solderless type	Fujitsu: FCN-367J040-AU/FW

Operating Environment

This module is compatible with all CPU module types.

Environment Specifications

Item	Specifications
Surrounding air temperature range	Operating : 0 to 55°C
	Storage : -20°C to 75°C
Surrounding humidity range	Operating : 10 to 90% RH (non-condensing)
	Storage : 10 to 90% RH (non-condensing)
Surrounding atmosphere	Must be free of corrosive gases, flammable gases or heavy dust.

Model and Suffix Codes

Model	Suffix Code	Style Code	Option Code	Description
F3YD32	-1P	32-point transistor output with short-circuit protector
F3YD64	-1P	64-point transistor output with short-circuit protector

External Dimensions

F3YD32-1P

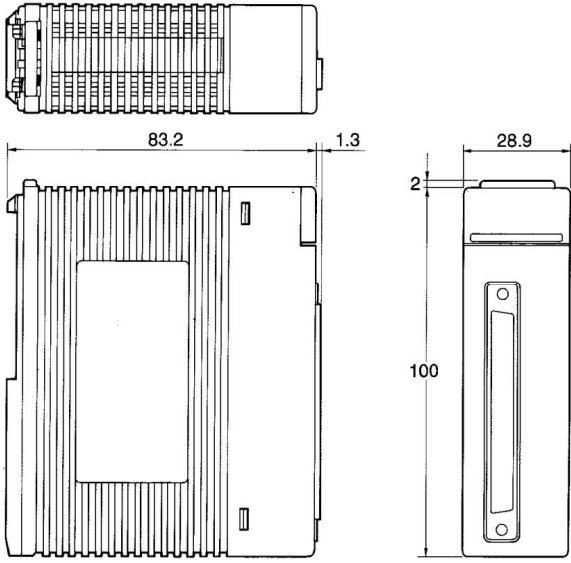

F3YD64-1P

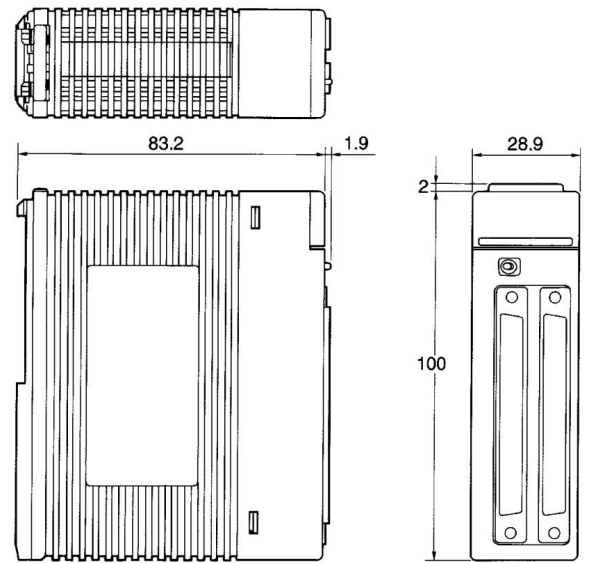

Unit: mm

Blank Page

General Specifications

F3YD32-1R, F3YD64-1R Transistor Output Modules (source type with short-circuit protector)

FA-M3

General

F3YD32-1R and F3YD64-1R are 32- and 64-point transistor output modules respectively.

Features

The modules have built-in protection against output short-circuit.

Specifications

Model	F3YD32-1R	F3YD64-1R
Output type	Transistor contact (source-type)	
Number of points	32	64
Common line type	8 points/common	
Isolation method	Photocoupler isolation	
Withstanding voltage	1500 V AC for one minute between the group of terminals for external connection and the internal circuit	
Rated load voltage ^{*1} (Operating voltage range)	12 to 24 V DC (10.2 to 26.4 V DC)	
Maximum load current	0.1 A/point 0.5 A/common	0.1 A/point 0.4 A/common
Response time	OFF→ON ON→OFF	1 ms max. 1 ms max.
ON voltage	0.5 V DC max.	
Off-time leak current	0.1 mA max.	
Service life	Mechanical	—
Protectors ^{*2}	Short-circuit	Controlled short-circuit current.
	Overheat	Output shutdown
Surge Protector ^{*3}	None	
Fuse	None	
Current consumption	170 mA (5 V DC)	275 mA (5 V DC)
Output display ^{*4}	LED (Lit when output is on)	LED (Lit when outputs are turned on for a switched LED group)
Output status when program stops ^{*5} HOLD/RESET	When a sequence CPU is used: Initial value: RESET All module outputs can be set collectively. ^{*6} When a BASIC CPU is used: No setting function; always set to HOLD	
External power supply ^{*1}	12 to 24 V DC 60 mA	12 to 24 V DC 110 mA
External connection	One 40-pin connector	Two 40-pin connectors
Weight	110 g	130 g

*1 The external power supply and the load power supply must be identical. Using separate power sources is not allowed even if they have the same voltage.

*2: Operation of the protection circuitry:

- If short-circuit occurs, the ON voltage increases and the short-circuit current is limited within the range 1-3 A.
- If the short-circuit condition is removed, normal operation resumes.
- If the short-circuit condition persists, the short-circuit current may cause the temperature of the output element to reach approx. 160°C, triggering the overheat protector to shut down the output.
- If the temperature of the overheated output element then drops by about 10°C, normal operation resumes.
- The overheat protector will not be triggered if the module is operated normally within its specifications with no short-circuit condition.
- Short-circuit protectors are designed to control outputs individually. On the other hand, the overheat protectors control outputs in pairs: OUT1 and OUT2, OUT3 and OUT4, ..., OUT63 and OUT64. Under some short-circuit conditions, however, an overheat protector may shut down not only its associated outputs but also other outputs.

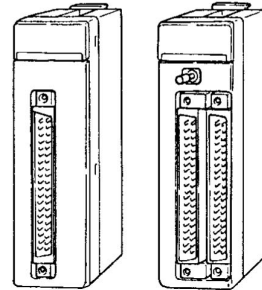

- Short-circuit and overheat protectors are designed to protect the output element against short-term short-circuit. Never leave the module in prolonged short-circuit condition. Otherwise, the module enclosure may deteriorate or the PCB may be discolored.
- Ensure that the polarity of the external power supply is correct. Otherwise, a short-circuit condition may damage an output element, and cause smoldering and scattering of chips.
- Beware that wrongly connecting a connector wired for F3XD32 or F3XD64 to the module may disable the protectors and damage internal elements.
- *3: If an inductive load, such as a relay, is to be connected, a surge protector is also required on the load side. Connect a surge protector or a diode across the load nearby so that the module output terminal voltage will not exceed the specified operating load voltage range.
- *4: The contact operation of the output block of the circuit and the LED display operate independently and thus may be inconsistent in the event of an error.
- *5: For details on the module's behavior when the CPU fails, see the Severity of Failures and LED Display* in the FA-M3 Range-free Multi-controller (GS 34M06A01-01E).
- *6: When F3SP28, F3SP38, F3SP5x, F3SP6x or F3SP7x is used, all points can be specified in 16-point units.

Components and Functions

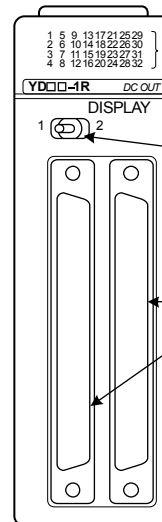

Output LEDs
Indicates the on/off status of the outputs.

Display Selector Switch
Switches display of output LEDs. Not present on 32-point modules.

One or two 40-pin connectors
32-point modules have only one connector.

Display Selector Switch Position	Output LEDs 1-32
1	Indicates on/off statuses of outputs 1 to 32.
2	Indicates on/off statuses of outputs 33 to 64.

External Connection Diagram

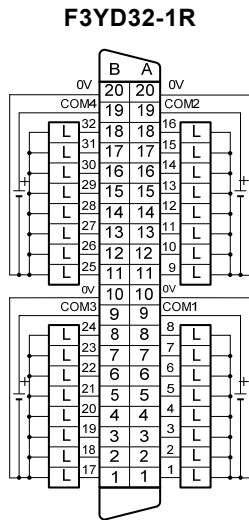

Note: Viewed from the front of the module.

F3YD64-1R

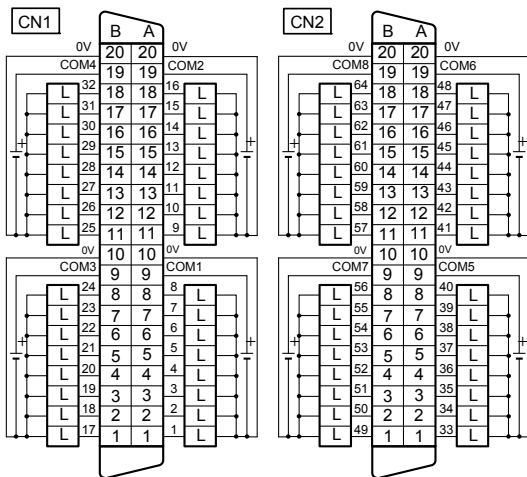

Note: Viewed from the front of the module.

Terminal Arrangement

32-point 64-point

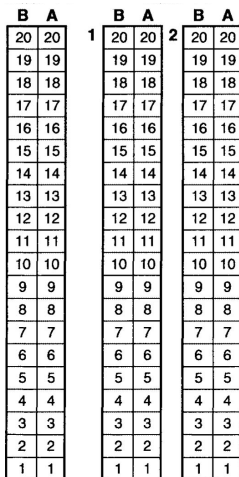

Internal Circuit Diagram

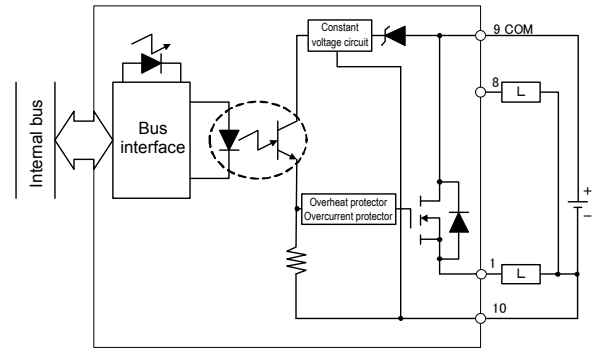

External Connection Method

Applicable conductor size	0.26 mm ² max.	0.08-0.20 mm ²	Flat cable, 1.27 mm pitch, 0.08 mm ²
Wire connection method	Soldered	Solderless	Solderless
Rated wire temperature	75°C min.		
Wire material	Copper		

Applicable External Connectors

Connection Method	Applicable Connector
Soldered type	Fujitsu: FCN-361J040-AU connector FCN-360C040-B connector cover
Solderless type	Fujitsu: FCN-363J040 connector FCN-363J-AU contact FCN-360C040-B connector cover
Solderless type	Fujitsu: FCN-367J040-AU/FW

Operating Environment

This module is compatible with all CPU module types.

Environment Specifications

Item	Specifications
Surrounding air temperature range	Operating : 0 to 55°C
	Storage : -20°C to 75°C
Surrounding humidity range	Operating : 10 to 90% RH (non-condensing)
	Storage : 10 to 90% RH (non-condensing)
Surrounding atmosphere	Must be free of corrosive gases, flammable gases or heavy dust.

Model and Suffix Codes

Model	Suffix Code	Style Code	Option Code	Description
F3YD32	-1R	32-point transistor output with short-circuit protector
F3YD64	-1R	64-point transistor output with short-circuit protector

External Dimensions

F3YD32-1R

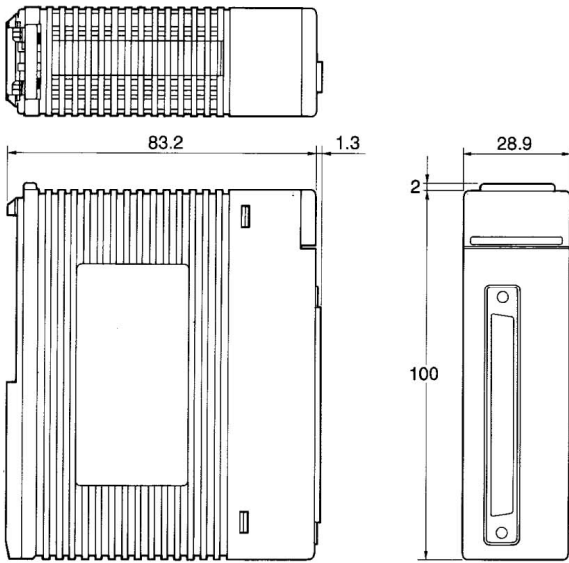

F3YD64-1R

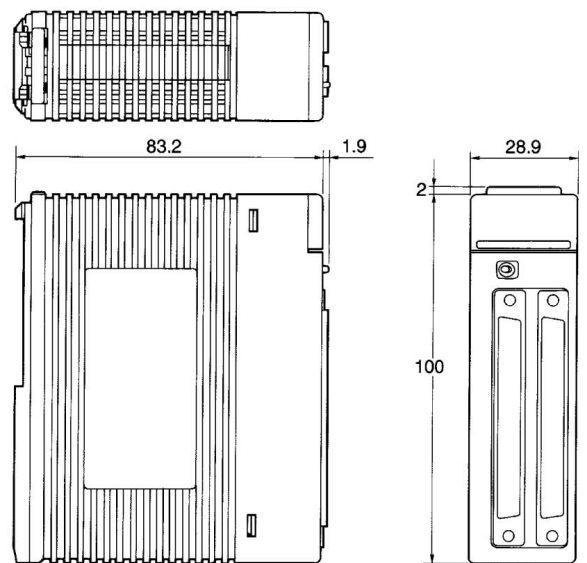

Unit: mm

Blank Page

General Specifications

F3WD64-xP Input/Output Module (sink type with short-circuit protector)

FA-M3

General

The F3WD64 Input/Output Module is intended for use in an input/output slot of the FA-M3. It has 32-point inputs and outputs (sink type) and is provided with two 40-pin connectors. Each input/output point is isolated from the internal circuit by a photocoupler. The F3WD64 input/output module uses an 8-point/common configuration for both input and output.

The operating voltage is either 12 V DC or 24 V DC.

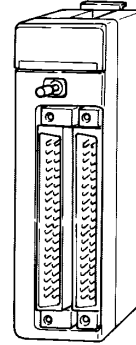

Features

The modules have built-in protection against output short-circuit.

Specifications

Item	F3WD64-3P	F3WD64-4P		
Input Block	Input type		DC voltage	
	Number of inputs		32 (Terminal Nos. 01 to 32)	
	Common line type		8 points/common	
	Isolation method		Photocoupler Isolation	
	Withstanding voltage		1500 V AC for one minute between the group of terminals for external connection and the internal circuit	
	Rated input voltage (Operating voltage range)		24V DC (20.4 to 26.4V DC) 12V DC (10.2 to 13.2V DC)	
	Rated input current		4.1 mA/point (24 V DC) 4.1 mA/point (12 V DC)	
	Operating voltage/current	ON	16 V DC min. 3.2 mA min.	8 V DC min. 2.6 mA min.
		OFF	5.8 V DC max. 0.9 mA max.	3.4 V DC max. 1.0 mA max.
	Response time	OFF→ON	Input sampling time can be specified for 4 steps : Always (0μs),62.5μs, 250μs and 1ms.	
		ON→OFF	Input sampling time can be specified for 4 steps : Always (0μs),62.5μs, 250μs and 1ms.	
Interrupt		None		
Maximum ratio of inputs turned on simultaneously		60%	100%	
Output Block	Output type		Transistor contact (sink type)	
	Number of outputs		32 (Terminal Nos. 33 to 64)	
	Common line type		8 points/common	
	Isolation method		Photocoupler isolation	
	Rated load voltage (Operating voltage range)		24 V DC (20.4 to 26.4 V DC) 12 V DC (10.2 to 13.2 V DC)	
	Maximum load current		0.1 A/point 0.4 A/common	
	Response time	OFF→ON	1 ms max.	
		ON→OFF	1 ms max.	
	ON voltage		0.5 V DC max.	
	OFF-time leakage current		0.1 mA max.	
	Protectors ²	Short-circuit	Controlled short-circuit current	
Overheat		Output shutdown		
Surge Protector ³		Active clamp circuit		
Fuse		None		
Output status when program stops ⁴ HOLD/RESET		When a sequence CPU is used: Default: RESET Can be set globally on a module-by-module basis ⁵ When a BASIC CPU is used: No setting function; the status is always HOLD.		
External power supply		24 V DC, 55 mA	12 V DC, 55 mA	
Common	Withstanding voltage		1500 V AC for one minute between the group of terminals for external connection and the internal circuit	
	Input/Output status indication ⁶		Lit when status is on (Input or output status indication can be selected using a switch.)	
	Current consumption		170 mA (5V DC)	
	External connection		Two 40-pin connectors	
Weight		120 g		

- *1: When F3SP28, F3SP38, F3SP5x, F3SP6x or F3SP7x is used. For other CPU modules, the OFF → ON response time is 1.0 ms (max.) and the OFF → ON response time is 2.5 ms (max.). The actual response time can be obtained by adding the following values:
 - 100 μs (OFF → ON)
 - 300 μs (ON → OFF)
 If the input interrupt is to be used, set the input sampling period to at least 62.5 μs.
- *2: Operation of the protection circuitry:
 - If short-circuit occurs, the ON voltage increases and the short-circuit current is limited within the range 1-3 A.
 - If the short-circuit condition is removed, normal operation resumes.
 - If the short-circuit condition persists, the short-circuit current may cause the temperature of the output element to reach approx. 160°C, triggering the overheat protector to shut down the output.
 - If the temperature of the overheated output element then drops by about 10°C, normal operation resumes.
 - The overheat protector will not be triggered if the module is operated normally within its specifications with no short-circuit condition.
 - Both the short-circuit protector and overheat protector are designed to control outputs individually. Under some short-circuit conditions, however, the overheat protector may shut down not only its associated output but also other outputs.
 - Short-circuit and overheat protectors are designed to protect the output element against short-term short-circuit. Never leave the module in prolonged short-circuit condition. Otherwise, the module enclosure may deteriorate or the PCB may be discolored.
 - Ensure that the polarity of the external power supply is correct. Otherwise, a short-circuit condition may damage an output element, and cause smoldering and scattering of chips. Beware that wrongly connecting a connector wired for F3XD32 or F3XD64 to the module may disable the protectors and damage internal elements.
- *3: If an inductive load, such as a relay, is to be connected, a surge protector is also required on the load side. Connect a surge protector or a diode across the load nearby so that the module output terminal voltage will not exceed the specified operating load voltage range.
- *4: For details on the module behavior when the CPU fails, see the Severity of Failures and LED Display” in the FA-M3 Range-free Multi-controller (GS 34M06A01-01E).
- *5: When F3SP28, F3SP38, F3SP5x, F3SP6x or F3SP7x is used, all points can be specified in 16-point units.
- *6: The contact operation of the output block of the circuit and the LED display operate independently and thus may be inconsistent in the event of an error.

Components and Functions

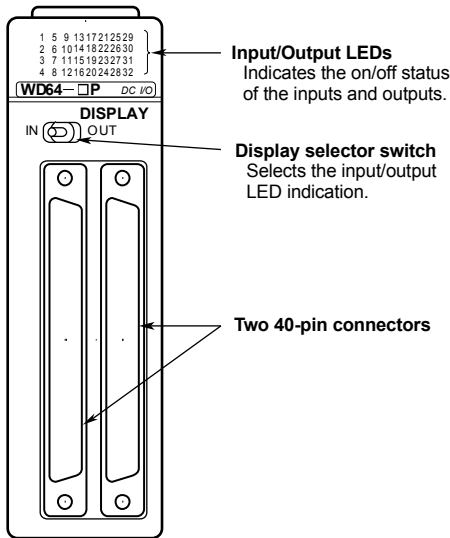

Display selector switch position	LED Indication
IN	Indicates the on/off status of inputs 1 to 32.
OUT	Indicates the on/off status of outputs 33 to 64.

Internal Circuit Diagram

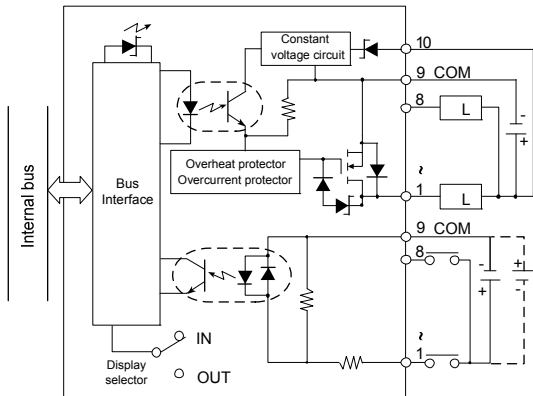

External Connection Diagram

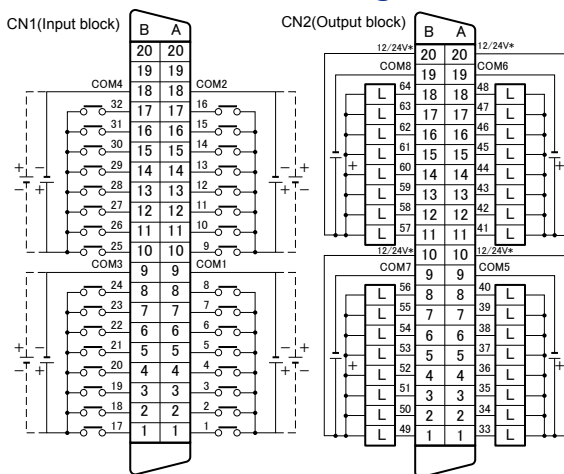

Note : Viewed from the front of the module.
* : 24 V for F3WD64-3P and 12 V for F3WD64-4P.

Terminal Arrangement

	B	A	B	A
1	20	20	20	20
	19	19	19	19
	18	18	18	18
	17	17	17	17
	16	16	16	16
	15	15	15	15
	14	14	14	14
	13	13	13	13
	12	12	12	12
	11	11	11	11
	10	10	10	10
	9	9	9	9
	8	8	8	8
	7	7	7	7
	6	6	6	6
	5	5	5	5
	4	4	4	4
	3	3	3	3
	2	2	2	2
	1	1	1	1

External Connection Method

	Connector Type		
Applicable conductor size	0.26 mm ² max.	0.08 - 0.20 mm ²	Flat cable, 1.27 mm pitch, 0.08 mm ²
Wire connection method	Soldered	Solderless	Solderless
Rated wire temperature	75 °C min.		
Wire Material	Copper		

Applicable External Connectors

Connection Method	Applicable Connector
Soldered type	Fujitsu : FCN-361J040- AU connector FCN-360C040-B connector cover
Solderless type	Fujitsu : FCN-363J040 housing FCN-363J- AU contact FCN-360C040-B connector cover
Solderless type	Fujitsu : FCN-367J040- AU / FW

Operating Environment

There is no restriction on the type of CPU modules that can be used with this module.

Environment Specifications

Item	Specifications
Surrounding air temperature range	Operating : 0 to 55°C
	Storage : -20°C to 75°C
Surrounding humidity range	Operating : 10 to 90% RH (non-condensing)
	Storage : 10 to 90% RH (non-condensing)
Surrounding atmosphere	Must be free of corrosive gases, flammable gases or heavy dust.

Model and Suffix Codes

Model	Suffix code	Style code	Option code	Description
F3WD64	-3P	24 V DC input/output (with short-circuit protector)
F3WD64	-4P	12 V DC input/output (with short-circuit protector)

*: See the section on spare parts in the FA-M3 Range-free Multi-controller (GS 34M06A01-01E) for information on connectors.

External Dimensions

F3WD64-xP

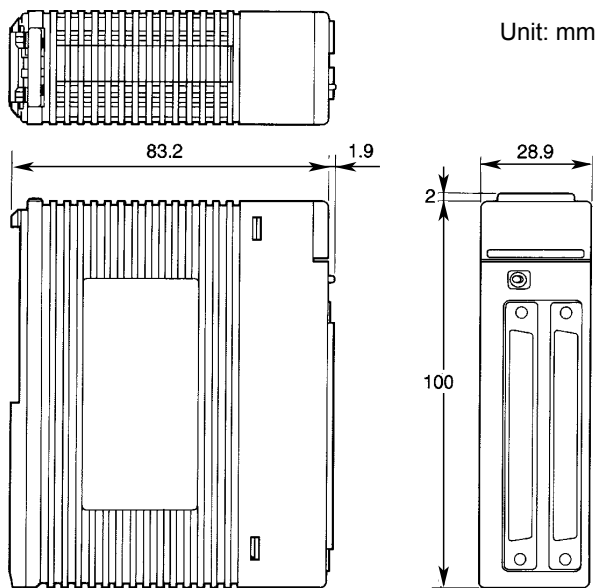

Blank Page

General Specifications

TA40-0N Terminal Block Unit

FA-M3

General

The TA40-0N Terminal Block Unit is intended for use in the input/output modules that conform to the connector specifications of the FA-M3 Range-free Multi-controller. It allows direct wiring for its slim connector profile. The TA40-0N can be used effectively not only for permanent connections but also for temporary connections such as during debugging.

- The ultra-slim connector saves space on the power switch board.
- It permits direct mounting on an input/output module, which leads to cost reduction and dispenses with the need for cables.
- It can be used with all FA-M3 40-pin input/ output connectors.
- Using a European type terminal block relieves the user from the burden of soldering or crimping.
- It can be secured on an input/output module with screws to facilitate stable operation.

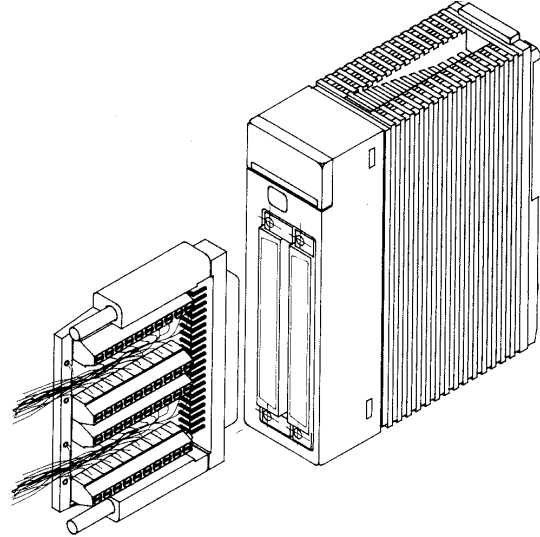

Specifications

Item	Specification
Number of points	40
Rated voltage	5-24 V DC
Operating voltage range	4.5 - 26.4 V DC
Maximum current	0.5 A DC / 1 point
Applicable conductor size	0.08 - 0.26 mm ² (AWG23 - 28)
Terminal block screw	M2 (slotted head screw)
Clamping screw	M2.6 (cross head screw)
Color	Black
Weight	50 g

Note: The connector terminal block cannot be used with the F3YP04, F3YP08, F3YP14, F3YP18, F3NC32 and F3NC34 modules.

Environment Specifications

Item	Specifications
Surrounding air temperature range	Operating : 0 to 55°C
	Storage : -20°C to 75°C
Surrounding humidity range	Operating : 10 to 90% RH (non-condensing)
	Storage : 10 to 90% RH (non-condensing)
Surrounding atmosphere	Must be free of corrosive gases, flammable gases or heavy dust.

External Dimensions

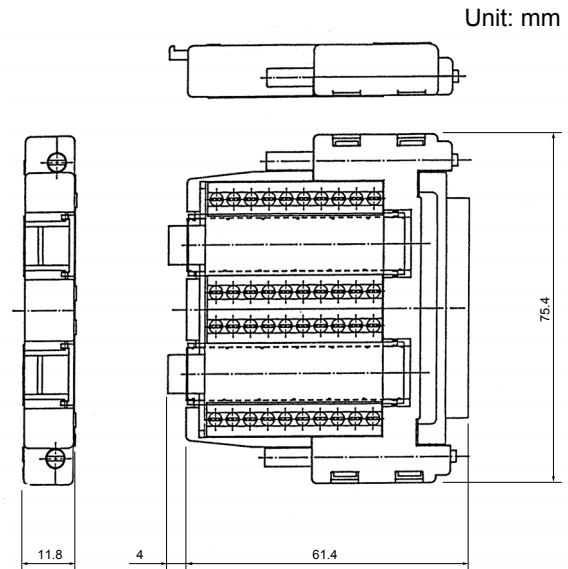

Model and Suffix Codes

Model	Suffix code	Style code	Option code	Description
TA40	-0N	Terminal block unit, 40 points

Blank Page

General Specifications

TA50-0N/ TA50-1N/ TA50-2N Connector Terminal Block Unit KM55-0xx Connector Terminal Block Cable

FA-M3

General

The TA50-0N, TA50-1N and TA50-2N Connector Terminal Block Units are intended for use in the input/output modules that conform to the connector specifications of the FA-M3 Range-free Multi-controller

- The TA50-0N and TA50-1N are connected to an input/output unit via the KM55-0xx Connector Terminal Block, which saves space and reduces wiring on the power switch board.
- Use of the connector terminal block unit with the connector terminal block cable eliminates soldering work for wiring.
- The TA50-0N and TA50-1N can be secured with mounting screws or DIN rails.

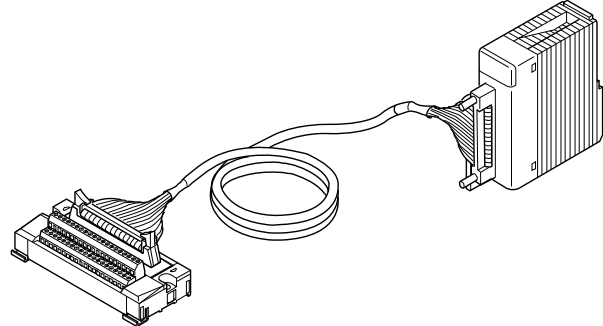

Specifications (TA50-xN)

Item	Specification		
	TA50-0N	TA50-1N	TA50-1N
Number of points	40		
Rated voltage	5-24 V DC		
Operating voltage range	4.5 - 26.4 V DC		
Maximum current	0.5 A DC / 1 point		
Applicable conductor size	2 mm ² max.	1.25 mm ² max.	
Terminal block screw	M3.5	M3	
Applicable terminal	Solderless ø8 mm max.	Solderless ø5.8 mm max.	
Connector	HIF3BA-40PA-2.54DSA (71) (MIL standard compliant)		
Mounting method	35-mm wide DIN rail or screw mounting		
Clamping screw	M4 (2 points)		
Color	Black	Gray	
Weight	300 g	175 g	162g

Note: The connector terminal blocks cannot be used with the F3YP04, F3YP08, F3YP14, F3YP18, F3YP22, F3YP24, F3YP28, F3NC32 and F3NC34 modules.

Environment Specifications (TA50-xN)

Item	Specifications
Surrounding air temperature range	Operating : 0 to 55°C
	Storage : -20°C to 75°C
Surrounding humidity range	Operating : 10 to 90% RH (non-condensing)
	Storage : 10 to 90% RH (non-condensing)
Surrounding atmosphere	Must be free of corrosive gases, flammable gases or heavy dust.

Specifications (KM55-0xx)

Item	Specification
KM55-005	0.5 m
KM55-010	1.0 m
KM55-015	1.5 m
KM55-020	2.0 m
KM55-025	2.5 m
KM55-030	3.0 m

Note: As the connector terminal block does not come with a cable for connecting a module and a connector terminal block, select a suitable cable from the list above.

Terminal Arrangement (TA50-0N)

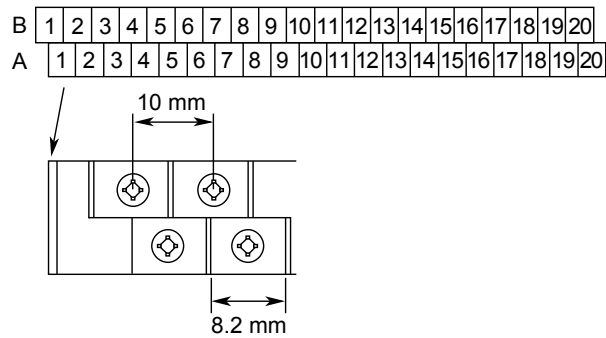

Terminal Arrangement (TA50-1N/TA50-2N)

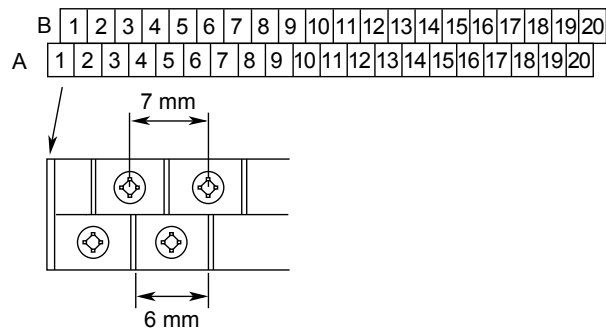

Internal Connection Diagram

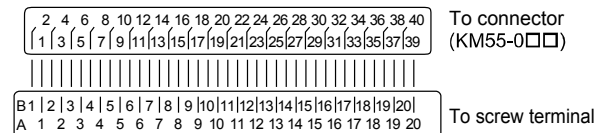

Note: The pin assignment of the screw terminal matches that of the module connectors.

External Dimensions

● TA50-0N

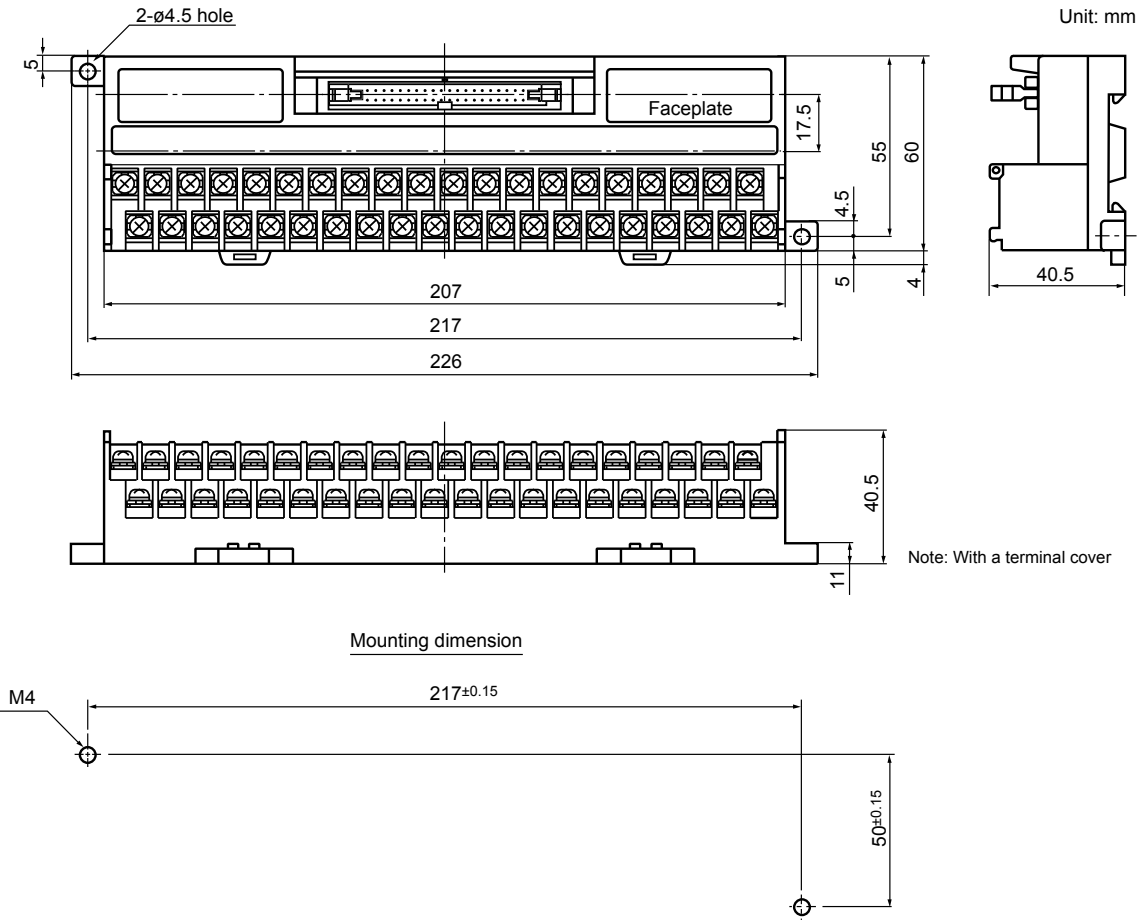

● TA50-1N

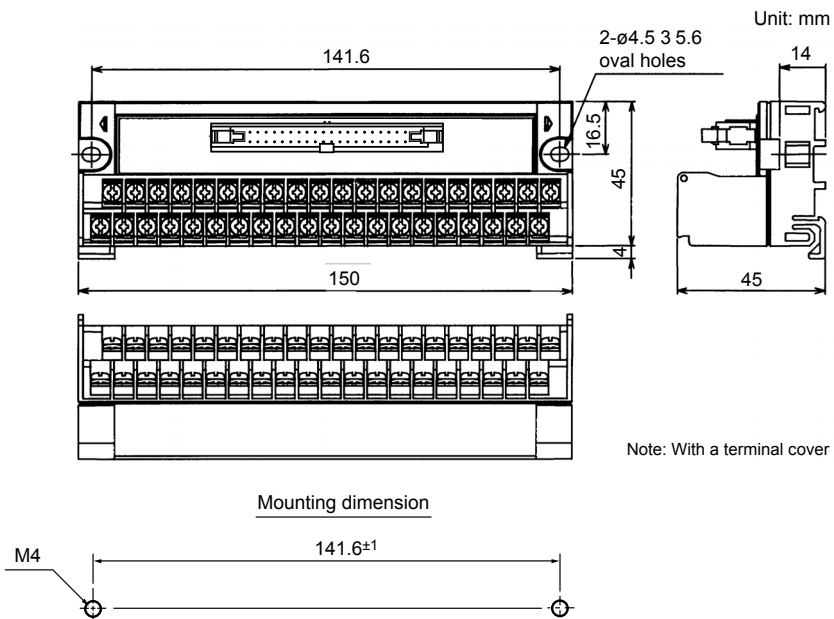

● TA50-2N

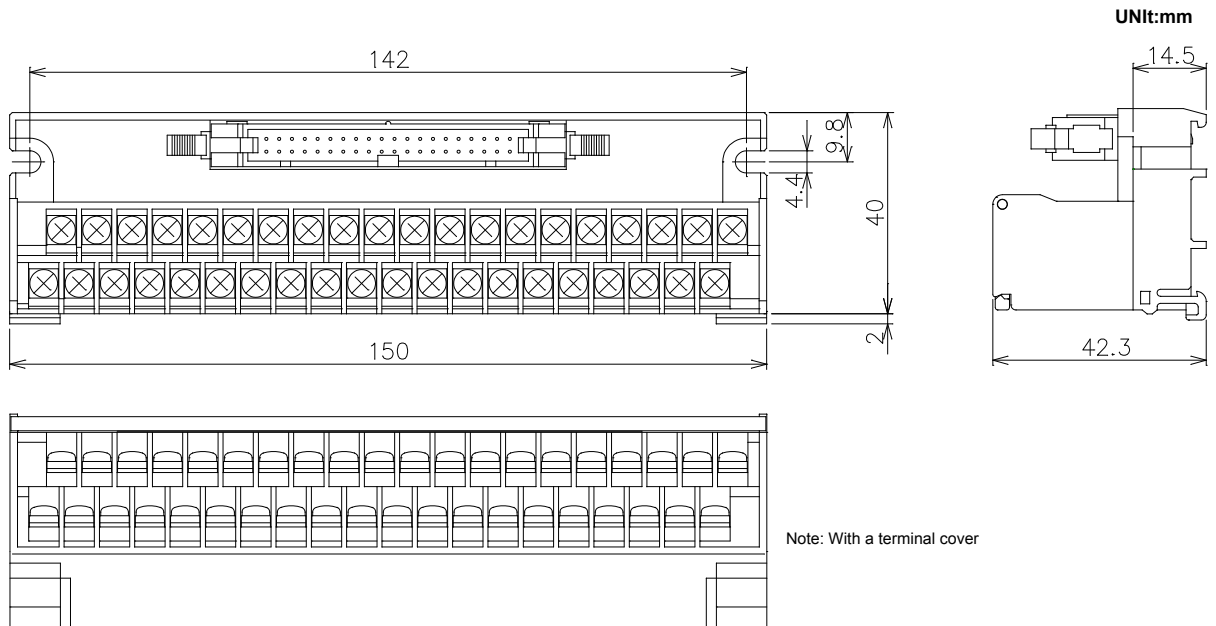

Mounting dimension



● KM55-0xx

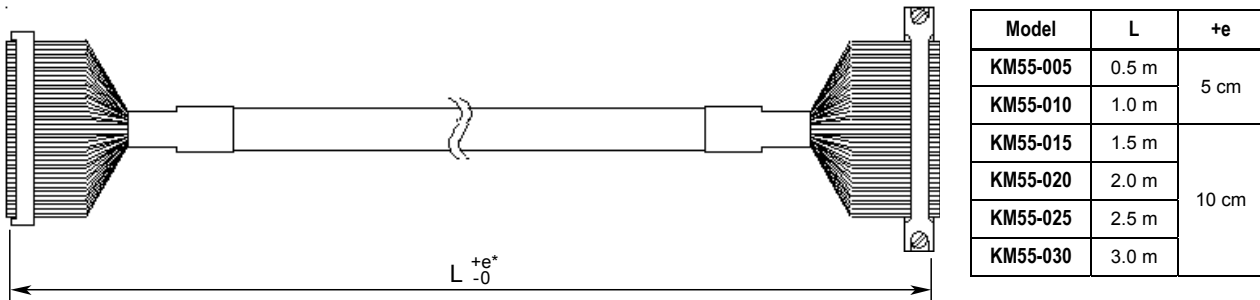

Model and Suffix Codes

Model	Suffix code	Style code	Option code	Description
TA50	-0N	Connector terminal block unit, 40 points (M3.5 screw)
	-1N	Connector terminal block unit, 40 points (M3 screw)
	-2N	Connector terminal block unit, 40 points (M3 screw)
KM55	-005	Connector terminal block cable, 0.5 m
	-010	Connector terminal block cable, 1.0 m
	-015	Connector terminal block cable, 1.5 m
	-020	Connector terminal block cable, 2.0 m
	-025	Connector terminal block cable, 2.5 m
	-030	Connector terminal block cable, 3.0 m

Blank Page