



# Remote I/O Scanner

(Catalog Number 1747-SN)

plcdcspro@cambia.cn

<b>Inside .....</b>	<b>page</b>
For More Information .....	2
Hazardous Location Considerations .....	3
Environnements dangereux .....	3
Overview .....	4
Hardware Features .....	5
Required Tools and Equipment .....	8
Installation .....	8
RIO Link Wiring .....	10
Specifications .....	12

## For More Information

For	Refer to this Document	Pub. No.
A more detailed description on how to install, configure, and operate your Remote I/O Scanner.	Remote I/O Scanner User Manual	1747-6.6
A more detailed description on how to install and use your modular SLC 500 system	SLC 500 Modular Hardware Style Installation and Operation Manual	1747-UM011
A reference manual that contains status file data and instruction set information for SLC 500 processors.	SLC 500 Instruction Set Reference Manual	1747-RM001

If you would like a manual you can:

- download a free electronic version from the internet:  
**www.theautomationbookstore.com**
- purchase a printed manual by:
  - contacting your local distributor or Rockwell Automation representative
  - visiting **www.theautomationbookstore.com** and placing your order
  - calling **1.800.963.9548** (USA/Canada) or  
**001.330.725.1574** (Outside USA/Canada)

---

## Hazardous Location Considerations

This equipment is suitable for use in Class I, Division 2, Groups A, B, C, D or non-hazardous locations only. The following WARNING statement applies to use in hazardous locations.

---

**WARNING****EXPLOSION HAZARD**

- Substitution of components may impair suitability for Class I, Division 2.
  - Do not replace components or disconnect equipment unless power has been switched off.
  - Do not connect or disconnect components unless power has been switched off.
  - All wiring must comply with N.E.C. article 501-4(b).
- 

## Environnements dangereux

Cet équipement est conçu pour être utilisé dans des environnements de Classe I, Division 2, Groupes A, B, C, D ou non dangereux. La mise en garde suivante s'applique à une utilisation dans des environnements dangereux.

---

**WARNING****DANGER D'EXPLOSION**

- La substitution de composants peut rendre cet équipement impropre à une utilisation en environnement de Classe I, Division 2.
  - Ne pas remplacer de composants ou déconnecter l'équipement sans s'être assuré que l'alimentation est coupée.
  - Ne pas connecter ou déconnecter des composants sans s'être assuré que l'alimentation est coupée.
-

## Overview

The Remote I/O (RIO) Scanner, 1747-SN, enables communication between an SLC™ processor and remotely located 1746 I/O chassis and other RIO-compatible Allen-Bradley operator interface and control devices. The 1747-SN scanner communicates with remote devices using the A-B Remote I/O link. The RIO link consists of a single master (scanner) and multiple slaves (adapters). Communication between devices occurs over twisted-pair cable with the devices daisy-chained together. Maximum distance for remote communication is 3,048m (10,000 ft.). The scanner is compatible with any standard RIO adapter device.

The SLC processor transfers a maximum of 4 logical racks (32 input and 32 output image words) of discrete remote I/O data into the SLC input and output image files. You can adjust the size of the scanner image files during configuration of your SLC system so that the scanner only transfers the discrete I/O data required by your application program. The 1747-SN Series B or later RIO Scanner can be configured to transfer up to 64 words of data to a remote device via block transfer. Refer to publication 1747-6.6, *Remote I/O Scanner User Manual*, for information on configuration, programming, and block transfers.

The SLC 500™ processor (SLC 5/02 or higher) supports multiple scanners in its local I/O chassis. The maximum number is dependent on the following:

- backplane power requirements (power supply dependent)
- SLC 500 processor I/O data table limit (4,096 input and output bits)
- processor memory to support the application (SLC processor dependent)

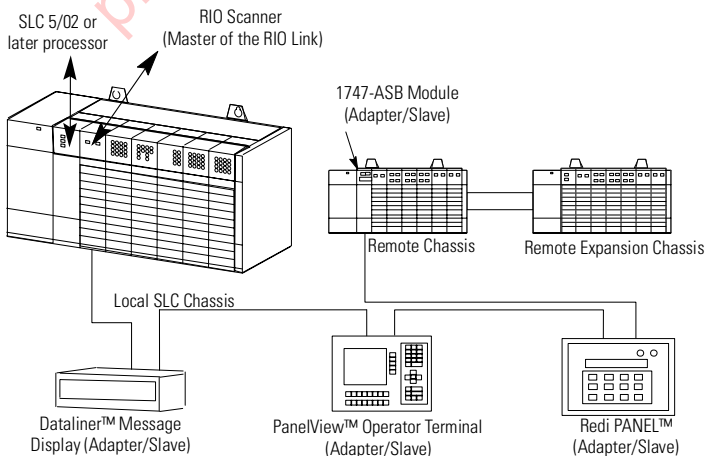

## Hardware Features

The figure below shows the scanner's features. RIO Link Connector, Status LED, and DIP Switch information follows.

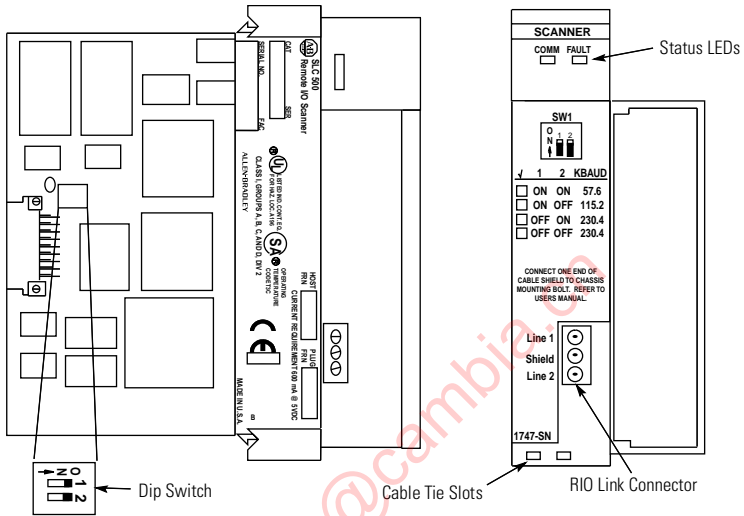

### RIO Link Connector

This 3-pin male connector connects the scanner to the RIO link. The Allen-Bradley replacement part number is 1746-RT29.

## Status LEDs

The scanner has two LEDs, FAULT and COMM, which indicate its operating status.

- **FAULT LED** - indicates the scanner's overall status. The red FAULT LED is off whenever the scanner is configured and operating properly.
- **COMM LED** - allows you to monitor communication with all configured devices. This LED is green once the scanner is in the Run mode. It is red if a hardware fault is detected. The COMM LED status information is valid only when the FAULT LED is off.

The table below explains the scanner and communication status as indicated by the FAULT and COMM LEDs.

FAULT LED	COMM LED	Status Information
Flashing Red	Not applicable	Scanner configuration error.
		No RIO link communication attempted.
		Duplicate scanner detected on RIO link.
Red	Not applicable	Major fault on scanner.
		No RIO link communication attempted.
Off	Red	Hardware fault detected.
Off	Off	Scanner is operating properly.
		Scanner is offline (no RIO link communication attempted).
Off	Green	Scanner is operating properly.
		Scanner is online (active communication established with all devices).
Off	Flashing Green	Scanner is operating properly.
		At least one configured RIO link device is not communicating.
Off	Flashing Red	Scanner is operating properly.
		None of the configured RIO link devices are communicating.

## Baud Rate DIP Switch

The figure below shows the location of the DIP switch and the DIP switch settings for the supported baud rates.

**IMPORTANT**

For proper system operation, the baud rate of all devices on the RIO link must be the same.

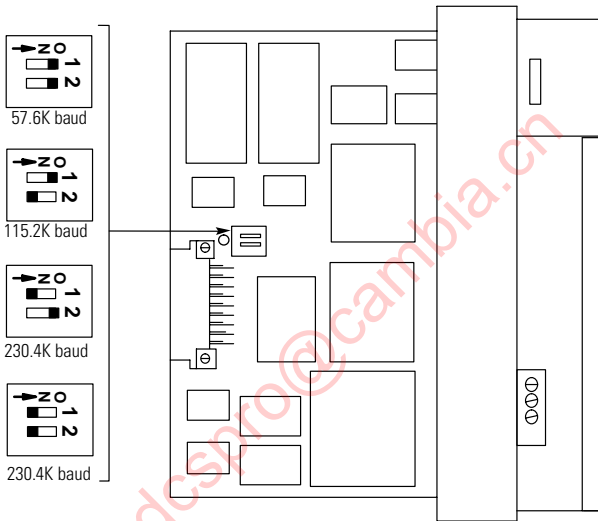

## Required Tools and Equipment

Have the following tools and equipment ready:

- medium blade screwdriver
- termination kit (the package, containing resistors and a ring lug, which was included with the scanner)
- approximately 38 cm (15 inches) of #20 AWG wire for grounding the drain shield to the SLC chassis (for Series A retrofits)
- adequate length of RIO communication cable (Belden™ 9463) for your specific application

## Installation

Make sure you have set the DIP switch properly before installing the scanner.

### IMPORTANT

Before installation, make sure that your modular SLC power supply has adequate reserve current capacity. The scanner requires 600 mA at 5V dc.

---

## Insertion

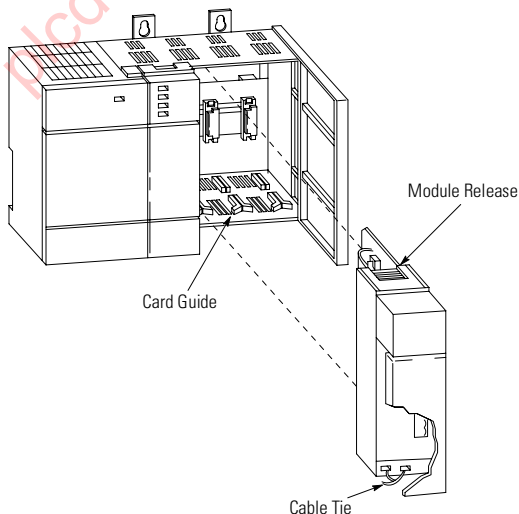



1. Disconnect power.
2. Align the full-sized circuit board with the chassis card guides. The first slot (slot 0) of the first rack is reserved for the SLC 500 processor.
3. Slide the module into the chassis until the top and bottom latches catch.
4. Attach the RIO link cable to the connector on the front of the module, behind the door. Ground the cable's shield wire to a chassis mounting bracket. Refer to the RIO link wiring illustration on page 10.
5. Insert the cable tie in the slots.
6. Route the cable down and away from module, securing it with the cable tie.
7. Cover all unused slots with the Card Slot Filler, Catalog Number 1746-N2.

## Removal

1. Disconnect power.
2. Remove all cabling.
3. Press the releases at the top and bottom of the module and slide the module out of the chassis slot.
4. Cover all unused slots with the Card Slot Filler, Catalog Number 1746-N2.

## RIO Link Wiring

The scanner is connected to other devices on the RIO link in a daisy-chain (serial) configuration. There are no restrictions governing the space between each device, provided the maximum cable distance (Belden 9463) is not exceeded. A 1/2 watt terminating resistor (included with the module) must be attached across line 1 and line 2 of the connectors at each end (scanner and last physical device) of the RIO link. The size of the resistor depends on the baud rate and extended node capability, as shown in the table below.

**Note:** To use extended node, all devices on the RIO link must support it. Refer to each device's user manual.

	Baud Rate	Max. Cable Distance (Belden 9463)	Resistor Size
<b>Using Extended Node Capability</b>	57.6K baud	3048 m (10,000 ft.)	82Ω 1/2 Watt Gray-Red-Black-Gold
	115.2K baud	1524 m (5,000 ft.)	
	230.4K baud	762 m (2,500 ft.)	
<b>Not Using Extended Node Capability</b>	57.6K baud	3048 m (10,000 ft.)	150Ω 1/2 Watt Brown-Green-Brown-Gold
	115.2K baud	1524 m (5,000 ft.)	
	230.4K baud	762 m (2,500 ft.)	82Ω 1/2 Watt Gray-Red-Black-Gold

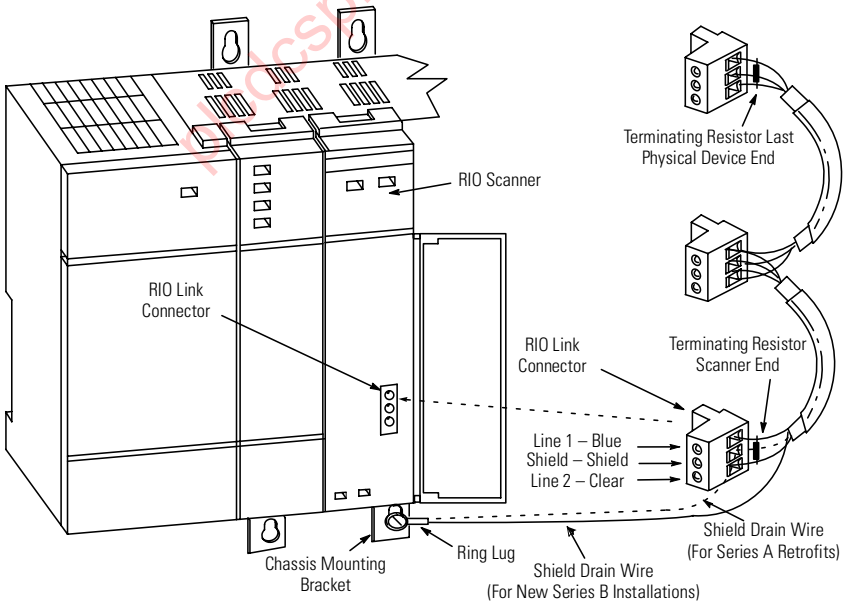

---

## For New Installations

To ensure a proper earth ground of the cable shield, follow these steps:

1. While the RIO link connector is plugged into the scanner and lines 1 and 2 are connected, strip the cable back to expose enough shield drain wire to reach a chassis mounting bracket.
2. Attach the ring terminal lug (supplied) to the end of the shield drain wire.
3. Attach the ring terminal lug to the SLC chassis mounting bracket. Note that for new installations the middle (shield) terminal is not used when connecting to the scanner.

---

**IMPORTANT**

The RIO cable shield must be grounded at the scanner end only.

---

## For Series A Scanner Retrofits

Refer to the illustration on page 10. To eliminate the need to strip the cable back, follow these steps:

1. Attach the shield wire and a short piece of #20 AWG wire (dotted line) to the shield lug of the RIO link connector.
2. Attach the other end of the #20 AWG wire to the ring terminal lug.
3. Attach the ring terminal lug to a chassis mounting bracket.

---

**IMPORTANT**

The RIO cable shield must be grounded at the scanner end only. Ensure that the unshielded portion of the link communication wire (blue and clear) is as short as possible.

---

# Specifications

Backplane Current Compensation	600 mA at 5V dc
Operating Temperature	0°C to +60°C (+32°F to +140°F)
Storage Temperature	-40°C to +85°C (-40°F to +185°F)
Humidity	5 to 95% without condensation
Noise Immunity	NEMA Standard ICS 2-230
Agency Certification	UL / C-UL listed Class I, Division 2, Groups A, B, C, D CE marked for all applicable directives C-Tick marked for all applicable acts

Rockwell Automation, Allen-Bradley, SLC 500, PanelView, RediPANEL, Dataliner, and TechConnect are trademarks of Rockwell Automation, Inc.

Trademarks not belonging to Rockwell Automation are property of their respective companies.

plcdcspro@cambia.cn

[www.rockwellautomation.com](http://www.rockwellautomation.com)

## Power, Control and Information Solutions Headquarters

Americas: Rockwell Automation, 1201 South Second Street, Milwaukee, WI 53204-2496 USA, Tel: (1) 414.382.2000, Fax: (1) 414.382.4444

Europe/Middle East/Africa: Rockwell Automation, Vorstlaan/Boulevard du Souverain 36, 1170 Brussels, Belgium, Tel: (32) 2 663 0600, Fax: (32) 2 663 0640

Asia Pacific: Rockwell Automation, Level 14, Core F, Cyberport 3, 100 Cyberport Road, Hong Kong, Tel: (852) 2887 4788, Fax: (852) 2508 1846

Publication 1747-IN060D-EN-P - November 2002

PN 40071-138-01(4)

Supersedes Publication 1747-IN060C-EN-P - March 2002

Copyright © 2007 Rockwell Automation, Inc. All rights reserved. Printed in Singapore.